

# HYDRAULIC MOTORS MP

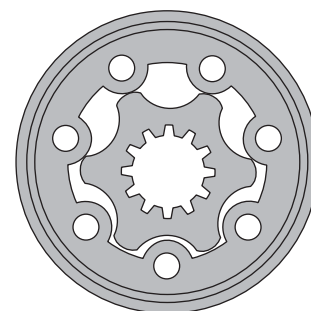

## APPLICATION

- » Conveyors
- » Feeding mechanism of robots and manipulators
- » Metal working machines
- » Textile machines
- » Agricultural machines
- » Food industries
- » Grass cutting machinery etc.



## CONTENTS

Specification data .....14÷17  
 Function diagrams .....18÷24  
 Dimensions and mounting ..... 25÷26  
 Wheel motor ..... 27  
 Shaft extensions ..... 28  
 Permissible shaft loads ..... 29  
 Permissible shaft Seal Pressure ... 30  
 Order code ..... 31

## OPTIONS

- » Model - Spool valve, gerotor
- » Flange and wheel mount
- » Motor with needle bearing
- » Side and rear ports
- » Shafts - straight, splined and tapered
- » Shaft seal for high and low pressure
- » Metric and BSPP ports
- » Speed sensing
- » Other special features

## GENERAL

<b>Max. Displacement,</b> cm <sup>3</sup> /rev [in <sup>3</sup> /rev]	623,6 [38.05]
<b>Max. Speed,</b> [RPM]	1815
<b>Max. Torque,</b> daNm [lb-in]	cont.:50 [4415] int.: 64 [5565]
<b>Max. Output,</b> kW [HP]	12,8 [17.1]
<b>Max. Pressure Drop,</b> bar [PSI]	cont.:140 [2030] int.: [175 [2540]
<b>Max. Oil Flow,</b> lpm [GPM]	75 [19.8]
<b>Min. Speed,</b> [RPM]	10
<b>Pressure fluid</b>	Mineral based- HLP(DIN 51524) or HM(ISO 6743/4)
<b>Temperature range,</b> °C [°F]	-40÷140 [-40÷284]
<b>Optimal Viscosity range,</b> mm <sup>2</sup> /s [SUS]	20÷75 [98÷347]
<b>Filtration</b>	ISO code 20/16 (Min. recommended fluid filtration of 25 microns)

### Oil flow in drain line

Pressure drop bar [PSI]	Viscosity mm <sup>2</sup> /s [SUS]	Oil flow in drain line lpm [GPM]
100 [1450]	20 [98]	2,5 [.660]
	35 [164]	1,8 [.476]
140 [2030]	20 [98]	3,5 [.925]
	35 [164]	2,8 [.740]

### Pressure Losses

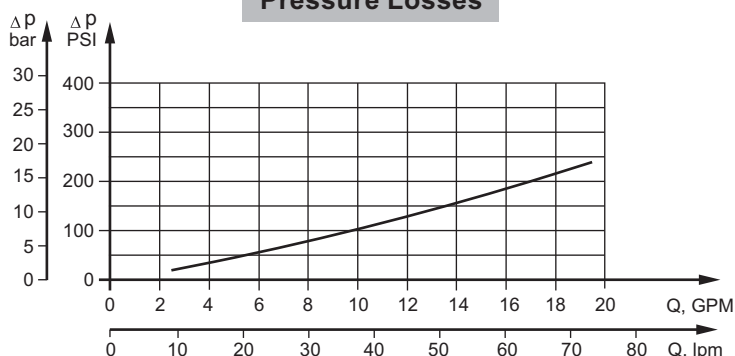

## SPECIFICATION DATA

Specification Data for MP... motors with **C, CO, SH, K** and **SA** shafts.  
( $\varnothing 28,56$  sealing diameter)

Type		MP 25	MP 32	MP 40	MP 50	MP 80	MP 100	MP 125
<b>Displacement, cm<sup>3</sup>/rev [in<sup>3</sup>/rev]</b>		28,4 [1.73]	34,5 [2,1]	40,5 [2.47]	49,5 [3.02]	79,2 [4.83]	99 [6.04]	123,8 [7.55]
<b>Max. Speed, [RPM]</b>	Cont.	1408	1450	1480	1210	755	605	486
	Int.*	1584	1594	1555	1515	945	755	605
<b>Max. Torque daNm [lb-in]</b>	Cont.	3,3 [290]	4,3 [380]	6,2 [550]	9,4 [835]	15,1 [1340]	19,3 [1710]	23,7 [2100]
	Int.*	4,7 [415]	6,1 [540]	8,2 [730]	11,9 [1050]	19,5 [1725]	23,7 [2100]	29,8 [2640]
	Peak**	6,7 [595]	8,6 [760]	10,7 [950]	14,3 [1285]	22,4 [1985]	27,5 [2435]	36,5 [3235]
<b>Max. Output kW [HP]</b>	Cont.	4,5 [6.0]	5,8 [7.8]	8,4 [11.5]	10,1 [13.5]	10,2 [13.7]	10,5 [14.1]	10,2 [13.7]
	Int.*	6,1 [8.2]	7,8 [10.5]	11,6 [15.5]	12,2 [16.1]	12,5 [16.8]	12,8 [17.1]	12 [16.1]
<b>Max. Pressure Drop bar [PSI]</b>	Cont.	100 [1450]	100 [1450]	120 [1750]	140 [2030]	140 [2030]	140 [2030]	140 [2030]
	Int.*	140 [2030]	140 [2030]	155 [2250]	175 [2540]	175 [2540]	175 [2540]	175 [2540]
	Peak**	225 [3260]	225 [3260]	225 [3260]	225 [3260]	225 [3260]	225 [3260]	225 [3260]
<b>Max. Oil Flow lpm [GPM]</b>	Cont.	40 [10.5]	50 [13.2]	60 [15.9]	60 [15.9]	60 [15.9]	60 [15.9]	60 [15.9]
	Int.*	45 [11.9]	55 [14.5]	70 [18.5]	75 [19.8]	75 [19.8]	75 [19.8]	75 [19.8]
<b>Max. Inlet Pressure bar [PSI]</b>	Cont.	175 [2540]	175 [2540]	175 [2540]	175 [2540]	175 [2540]	175 [2540]	175 [2540]
	Int.*	200 [2900]	200 [2900]	200 [2900]	200 [2900]	200 [2900]	200 [2900]	200 [2900]
	Peak**	225 [3260]	225 [3260]	225 [3260]	225 [3260]	225 [3260]	225 [3260]	225 [3260]
<b>Max. Return Pressure with Drain Line bar [PSI]</b>	Cont.	175 [2540]	175 [2540]	175 [2540]	175 [2540]	175 [2540]	175 [2540]	175 [2540]
	Int.*	200 [2900]	200 [2900]	200 [2900]	200 [2900]	200 [2900]	200 [2900]	200 [2900]
	Peak**	225 [3260]	225 [3260]	225 [3260]	225 [3260]	225 [3260]	225 [3260]	225 [3260]
<b>Max. Starting Pressure with Unloaded Shaft, bar [PSI]</b>		10 [145]	10 [145]	10 [145]	10 [145]	10 [145]	10 [145]	9 [131]
<b>Min. Starting Torque daNm [lb-in]</b>	At max.press. drop Cont.	3,0 [265]	4,0 [355]	5,4 [480]	7,8 [690]	13,2 [1170]	16,6 [1470]	20,7 [1830]
	At max.press. drop Int.*	4,2 [370]	5,6 [500]	6,8 [600]	10 [885]	16,8 [1490]	21 [1860]	26,6 [2360]
<b>Min. Speed***, [RPM]</b>		20	15	10	10	10	10	10
<b>Weight, kg [lb] For rear ports +0,450 [.992]</b>	MP(F)(N)	5,6 [12.3]	5,6 [12.3]	5,7 [12.6]	5,8 [12.8]	5,9 [13.2]	6,1 [13.5]	6,2 [13.7]
	MPW(N)	5,3 [11.7]	5,3 [11.7]	5,4 [11.9]	5,5 [12.1]	5,6 [12.4]	5,8 [12.8]	5,9 [13]
	MPQ(N)	5,0 [11.1]	5,0 [11.1]	5,1 [11.2]	5,2 [11.5]	5,3 [11.7]	5,5 [12.1]	5,6 [12.3]

\* Intermittent operation: the permissible values may occur for max. 10% of every minute.

\*\* Peak load: the permissible values may occur for max. 1% of every minute.

\*\*\* For speeds lower than given, consult factory or your regional manager.

- Intermittent speed and intermittent pressure must not occur simultaneously.
- Recommended filtration is per ISO cleanliness code 20/16. A nominal filtration of 25 micron or better.
- Recommend using a premium quality, anti-wear type mineral based hydraulic oil HLP(DIN51524) or HM (ISO 6743/4).  
If using synthetic fluids consult the factory for alternative seal materials.
- Recommended minimum oil viscosity 13 mm<sup>2</sup>/s [70 SUS] at 50°C [122°F].
- Recommended maximum system operating temperature is 82°C [180°F].
- To assure optimum motor life fill with fluid prior to loading and run at moderate load and speed for 10-15 minutes.

## SPECIFICATION DATA (continued)

Specification Data for MP... motors with **C**, **CO**, **SH**, **K** and **SA** shafts.  
(ø28,56 sealing diameter)

Type		MP 160	MP 200	MP 250	MP 315	MP 400	MP 500	MP 630
<b>Displacement, cm<sup>3</sup>/rev [in<sup>3</sup>/rev]</b>		158,4 [9.66]	198 [12.1]	247,5 [15.1]	316,8 [19.3]	396 [24.16]	495 [30.2]	623,6 [38.05]
<b>Max. Speed, [RPM]</b>	Cont.	378	303	242	190	150	120	95
	Int.*	472	378	303	236	189	150	120
<b>Max. Torque daNm [lb-in]</b>	Cont.	31,3 [2770]	36,6 [3240]	38 [3360]	38 [3360]	36 [3190]	39 [3452]	44 [3895]
	Int.*	37,8 [3345]	45,6 [4035]	58,3 [5160]	56 [4960]	59 [5240]	57 [5045]	64 [5665]
	Peak**	43,8 [3880]	55 [4870]	68,5 [6060]	85 [7505]	85,4 [7560]	78 [6903]	82 [7257]
<b>Max. Output kW [HP]</b>	Cont.	10,1 [13.5]	10 [13.5]	7,5 [10]	5,8 [7.9]	4,6 [6.2]	3,5 [4.7]	3,3 [4.4]
	Int.*	12,1 [16.2]	12 [16.1]	12 [16.1]	9 [12.1]	7,8 [10.5]	7,2 [9.7]	5,6 [7.5]
<b>Max. Pressure Drop bar [PSI]</b>	Cont.	140 [2030]	140 [2030]	110 [1600]	90 [1300]	70 [1015]	60 [870]	55 [800]
	Int.*	175 [2540]	175 [2540]	175 [2540]	140 [2030]	115 [1665]	90 [1305]	80 [1160]
	Peak**	225 [3260]	225 [3260]	225 [3260]	225 [3260]	180 [2610]	130 [1885]	110 [1740]
<b>Max. Oil Flow lpm [GPM]</b>	Cont.	60 [15.9]	60 [15.9]	60 [15.9]	60 [15.9]	60 [15.9]	60 [15.9]	60 [15.9]
	Int.*	75 [19.8]	75 [19.8]	75 [19.8]	75 [19.8]	75 [19.8]	75 [19.8]	75 [19.8]
<b>Max. Inlet Pressure bar [PSI]</b>	Cont.	175 [2540]	175 [2540]	175 [2540]	175 [2540]	175 [2540]	140 [2030]	140 [2030]
	Int.*	200 [2900]	200 [2900]	200 [2900]	200 [2900]	200 [2900]	175 [2540]	175 [2540]
	Peak**	225 [3260]	225 [3260]	225 [3260]	225 [3260]	225 [3260]	225 [3260]	225 [3260]
<b>Max. Return Pressure with Drain Line bar [PSI]</b>	Cont.	175 [2540]	175 [2540]	175 [2540]	175 [2540]	175 [2540]	140 [2030]	140 [2030]
	Int.*	200 [2900]	200 [2900]	200 [2900]	200 [2900]	200 [2900]	175 [2540]	175 [2540]
	Peak**	225 [3260]	225 [3260]	225 [3260]	225 [3260]	225 [3260]	225 [3260]	225 [3260]
<b>Max. Starting Pressure with Unloaded Shaft, bar [PSI]</b>		8 [116]	7 [100]	6 [87]	5 [73]	5 [73]	5 [73]	5 [73]
<b>Min. Starting Torque daNm [lb-in]</b>	At max.press. drop Cont.	28,2 [2500]	33,5 [2950]	33,6 [2970]	34,4 [3045]	34,5 [3050]	36 [3180]	41,5 [3670]
	At max.press. drop Int.*	35,5 [3140]	42,6 [3770]	54,2 [4795]	61,9 [5480]	60,8 [5390]	54 [4780]	62 [5480]
<b>Min. Speed***, [RPM]</b>		10	10	10	10	10	10	10
<b>Weight, kg [lb] For rear ports +0,450 [.992]</b>	MP(F)(N)	6,4 [14.1]	6,6 [14.6]	6,8 [15]	7,1 [15.6]	7,6 [16.8]	8,9 [20]	9,5 [21.4]
	MPW(N)	6,1 [13.5]	6,3 [13.9]	6,5 [14.3]	6,8 [15]	7,2 [15.9]	8,6 [19]	9,2 [20.3]
	MPQ(N)	5,8 [12.8]	6 [13.2]	6,2 [13.7]	6,5 [14.3]	6,8 [15]	8,3 [18.3]	9 [19.8]

\* Intermittent operation: the permissible values may occur for max. 10% of every minute.

\*\* Peak load: the permissible values may occur for max. 1% of every minute.

\*\*\* For speeds lower than given, consult factory or your regional manager.

- Intermittent speed and intermittent pressure must not occur simultaneously.
- Recommended filtration is per ISO cleanliness code 20/16. A nominal filtration of 25 micron or better.
- Recommend using a premium quality, anti-wear type mineral based hydraulic oil HLP(DIN51524) or HM ( ISO 6743/4).  
If using synthetic fluids consult the factory for alternative seal materials.
- Recommended minimum oil viscosity 13 mm<sup>2</sup>/s [70 SUS] at 50°C [122°F].
- Recommended maximum system operating temperature is 82°C [180°F].
- To assure optimum motor life fill with fluid prior to loading and run at moderate load and speed for 10-15 minutes.

## SPECIFICATION DATA (continued)

Specification Data for MP... motors with **CB, KB, OB** and **HB** shafts.  
( $\varnothing 35$  sealing diameter)

Type		MP 25	MP 32	MP 40	MP 50	MP 80	MP 100	MP 125
<b>Displacement, cm<sup>3</sup>/rev [in<sup>3</sup>/rev]</b>		28,4 [1.73]	34,5 [2,1]	40,5 [2.47]	49,5 [3.02]	79,2 [4.83]	99 [6.04]	123,8 [7.55]
<b>Max. Speed, [RPM]</b>	Cont.	1408	1450	1480	1210	755	605	486
	Int.*	1584	1594	1555	1515	945	755	605
<b>Max. Torque daNm [lb-in]</b>	Cont.	3,3 [290]	4,3 [380]	6,2 [550]	9,4 [835]	15,1 [1340]	19,3 [1710]	23,7 [2100]
	Int.*	4,7 [415]	6,1 [540]	8,2 [730]	11,9 [1050]	19,5 [1725]	23,7 [2100]	29,8 [2640]
	Peak**	6,7 [595]	8,6 [760]	10,7 [950]	14,3 [1285]	22,4 [1985]	27,5 [2435]	36,5 [3235]
<b>Max. Output kW [HP]</b>	Cont.	4,5 [6.0]	5,8 [7.8]	8,4 [11.5]	10,1 [13.5]	10,2 [13.7]	10,5 [14.1]	10,2 [13.7]
	Int.*	6,1 [8.2]	7,8 [10.5]	11,6 [15.5]	12,2 [16.1]	12,5 [16.8]	12,8 [17.1]	12 [16.1]
<b>Max. Pressure Drop bar [PSI]</b>	Cont.	100 [1450]	100 [1450]	120 [1750]	140 [2030]	140 [2030]	140 [2030]	140 [2030]
	Int.*	140 [2030]	140 [2030]	155 [2250]	175 [2540]	175 [2540]	175 [2540]	175 [2540]
	Peak**	225 [3260]	225 [3260]	225 [3260]	225 [3260]	225 [3260]	225 [3260]	225 [3260]
<b>Max. Oil Flow lpm [GPM]</b>	Cont.	40 [10.5]	50 [13.2]	60 [15.9]	60 [15.9]	60 [15.9]	60 [15.9]	60 [15.9]
	Int.*	45 [11.9]	55 [14.5]	70 [18.5]	75 [19.8]	75 [19.8]	75 [19.8]	75 [19.8]
<b>Max. Inlet Pressure bar [PSI]</b>	Cont.	175 [2540]	175 [2540]	175 [2540]	175 [2540]	175 [2540]	175 [2540]	175 [2540]
	Int.*	200 [2900]	200 [2900]	200 [2900]	200 [2900]	200 [2900]	200 [2900]	200 [2900]
	Peak**	225 [3260]	225 [3260]	225 [3260]	225 [3260]	225 [3260]	225 [3260]	225 [3260]
<b>Max. Return Pressure with Drain Line bar [PSI]</b>	Cont.	175 [2540]	175 [2540]	175 [2540]	175 [2540]	175 [2540]	175 [2540]	175 [2540]
	Int.*	200 [2900]	200 [2900]	200 [2900]	200 [2900]	200 [2900]	200 [2900]	200 [2900]
	Peak**	225 [3260]	225 [3260]	225 [3260]	225 [3260]	225 [3260]	225 [3260]	225 [3260]
<b>Max. Starting Pressure with Unloaded Shaft, bar [PSI]</b>		10 [145]	10 [145]	10 [145]	10 [145]	10 [145]	10 [145]	9 [131]
<b>Min. Starting Torque daNm [lb-in]</b>	At max.press. drop Cont.	3,0 [265]	4,0 [355]	5,4 [480]	7,8 [690]	13,2 [1170]	16,6 [1470]	20,7 [1830]
	At max.press. drop Int.*	4,2 [370]	5,6 [500]	6,8 [600]	10 [885]	16,8 [1490]	21 [1860]	26,6 [2360]
<b>Min. Speed***, [RPM]</b>		20	15	10	10	10	10	10
<b>Weight, kg [lb] For rear ports +0,450 [.992]</b>	MP(F)...B	5,6 [12.3]	5,6 [12.3]	5,7 [12.6]	5,9 [13]	6 [13.2]	6,2 [13.7]	6,3 [13.9]

\* Intermittent operation: the permissible values may occur for max. 10% of every minute.

\*\* Peak load: the permissible values may occur for max. 1% of every minute.

\*\*\* For speeds lower than given, consult factory or your regional manager.

1. Intermittent speed and intermittent pressure must not occur simultaneously.
2. Recommended filtration is per ISO cleanliness code 20/16. A nominal filtration of 25 micron or better.
3. Recommend using a premium quality, anti-wear type mineral based hydraulic oil HLP(DIN51524) or HM ( ISO 6743/4).  
If using synthetic fluids consult the factory for alternative seal materials.
4. Recommended minimum oil viscosity 13 mm<sup>2</sup>/s [70 SUS] at 50°C [122°F].
5. Recommended maximum system operating temperature is 82°C [180°F].
6. To assure optimum motor life fill with fluid prior to loading and run at moderate load and speed for 10-15 minutes.

## SPECIFICATION DATA (continued)

Specification Data for MP... motors with **CB, KB, OB** and **HB** shafts.  
( $\varnothing 35$  sealing diameter)

Type		MP 160	MP 200	MP 250	MP 315	MP 400	MP 500	MP 630
<b>Displacement, cm<sup>3</sup>/rev [in<sup>3</sup>/rev]</b>		158,4 [9.66]	198 [12.1]	247,5 [15.1]	316,8 [19.3]	396 [24.16]	495 [30.2]	623,6 [38.05]
<b>Max. Speed, [RPM]</b>	Cont.	378	303	242	190	150	120	95
	Int.*	472	378	303	236	189	150	120
<b>Max. Torque daNm [lb-in]</b>	Cont.	31,3 [2770]	36,6 [3240]	47 [4160]	48 [4360]	50 [4415]	39 [3452]	44 [3895]
	Int.*	37,8 [3345]	45,6 [4035]	58,3 [5160]	56 [4960]	59 [5240]	57 [5045]	64 [5665]
	Peak**	43,8 [3880]	55 [4870]	68,5 [6060]	85 [7505]	85,4 [7560]	78 [6903]	82 [7257]
<b>Max. Output kW [HP]</b>	Cont.	10,1 [13.5]	10 [13.5]	9 [12.1]	7,6 [10.2]	6,2 [8.3]	3,5 [4.7]	3,3 [4.4]
	Int.*	12,1 [16.2]	12 [16.1]	12 [16.1]	9 [12.1]	7,8 [10.5]	7,2 [9.7]	5,6 [7.5]
<b>Max. Pressure Drop bar [PSI]</b>	Cont.	140 [2030]	140 [2030]	140 [2030]	120 [1740]	95 [1400]	60 [870]	55 [800]
	Int.*	175 [2540]	175 [2540]	175 [2540]	140 [2030]	115 [1670]	90 [1305]	80 [1160]
	Peak**	225 [3260]	225 [3260]	225 [3260]	225 [3260]	180 [2610]	130 [1885]	110 [1740]
<b>Max. Oil Flow lpm [GPM]</b>	Cont.	60 [15.9]	60 [15.9]	60 [15.9]	60 [15.9]	60 [15.9]	60 [15.9]	60 [15.9]
	Int.*	75 [19.8]	75 [19.8]	75 [19.8]	75 [19.8]	75 [19.8]	75 [19.8]	75 [19.8]
<b>Max. Inlet Pressure bar [PSI]</b>	Cont.	175 [2540]	175 [2540]	175 [2540]	175 [2540]	175 [2540]	140 [2030]	140 [2030]
	Int.*	200 [2900]	200 [2900]	200 [2900]	200 [2900]	200 [2900]	175 [2540]	175 [2540]
	Peak**	225 [3260]	225 [3260]	225 [3260]	225 [3260]	225 [3260]	225 [3260]	225 [3260]
<b>Max. Return Pressure with Drain Line bar [PSI]</b>	Cont.	175 [2540]	175 [2540]	175 [2540]	175 [2540]	175 [2540]	140 [2030]	140 [2030]
	Int.*	200 [2900]	200 [2900]	200 [2900]	200 [2900]	200 [2900]	175 [2540]	175 [2540]
	Peak**	225 [3260]	225 [3260]	225 [3260]	225 [3260]	225 [3260]	225 [3260]	225 [3260]
<b>Max. Starting Pressure with Unloaded Shaft, bar [PSI]</b>		8 [116]	7 [100]	6 [87]	5 [73]	5 [73]	5 [73]	5 [73]
<b>Min. Starting Torque daNm [lb-in]</b>	At max.press. drop Cont.	28,2 [2500]	33,5 [2950]	42,8 [3790]	4050 [45,8]	46,8 [4140]	36 [3180]	41,5 [3670]
	At max.press. drop Int.*	35,5 [3140]	42,6 [3770]	54,2 [4795]	5480 [61,9]	60,8 [5390]	54 [4780]	62 [5480]
<b>Min. Speed***, [RPM]</b>		10	10	10	10	10	10	10
<b>Weight, kg [lb] For rear ports +0,450 [.992]</b>	MP(F)...B	6,5 [14.3]	6,7 [14.8]	6,9 [15.2]	7,2 [15.9]	7,7 [17]	9,0 [19.9]	9,6 [21.2]

\* Intermittent operation: the permissible values may occur for max. 10% of every minute.

\*\* Peak load: the permissible values may occur for max. 1% of every minute.

\*\*\* For speeds lower than given, consult factory or your regional manager.

1. Intermittent speed and intermittent pressure must not occur simultaneously.
2. Recommended filtration is per ISO cleanliness code 20/16. A nominal filtration of 25 micron or better.
3. Recommend using a premium quality, anti-wear type mineral based hydraulic oil HLP(DIN51524) or HM ( ISO 6743/4).  
If using synthetic fluids consult the factory for alternative seal materials.
4. Recommended minimum oil viscosity 13 mm<sup>2</sup>/s [70 SUS] at 50°C [122°F].
5. Recommended maximum system operating temperature is 82°C [180°F].
6. To assure optimum motor life fill with fluid prior to loading and run at moderate load and speed for 10-15 minutes.

**FUNCTION DIAGRAMS**

**MP 25**

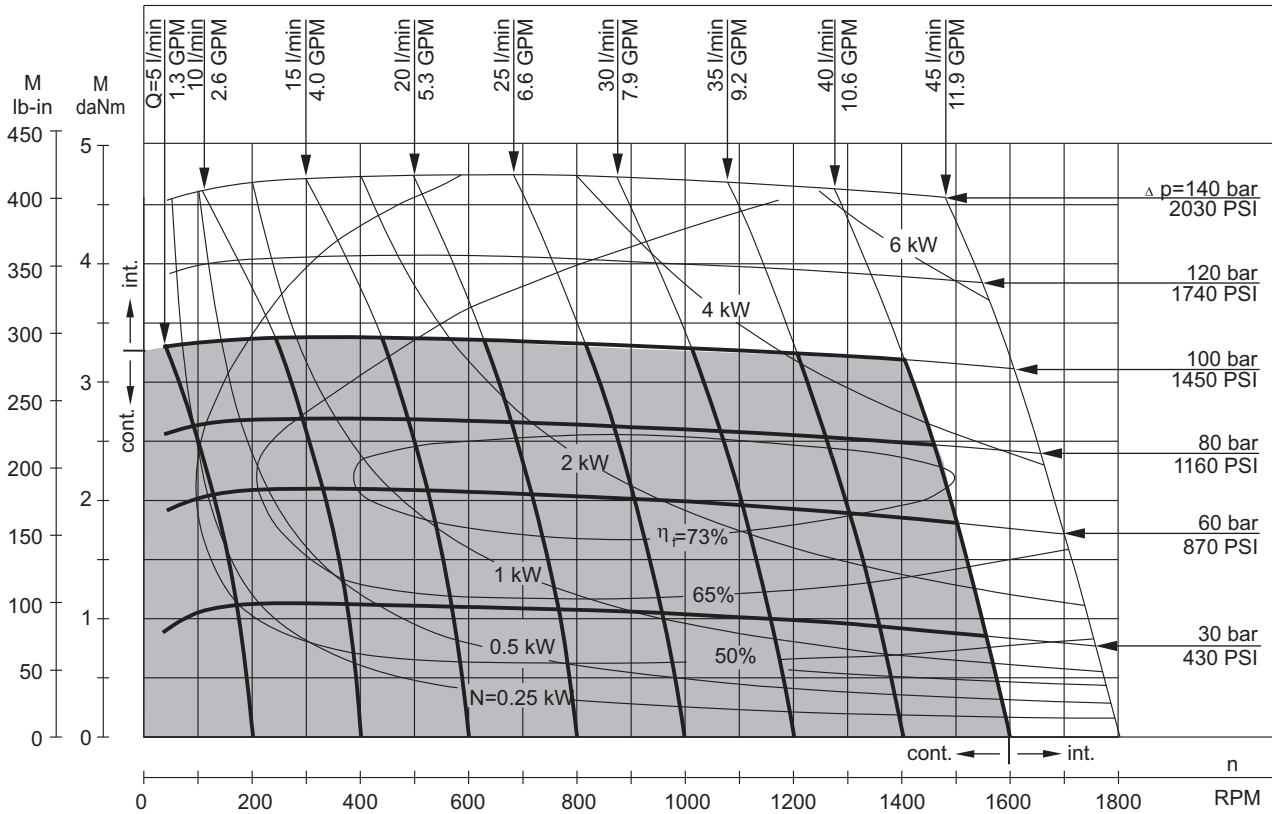

**MP 32**

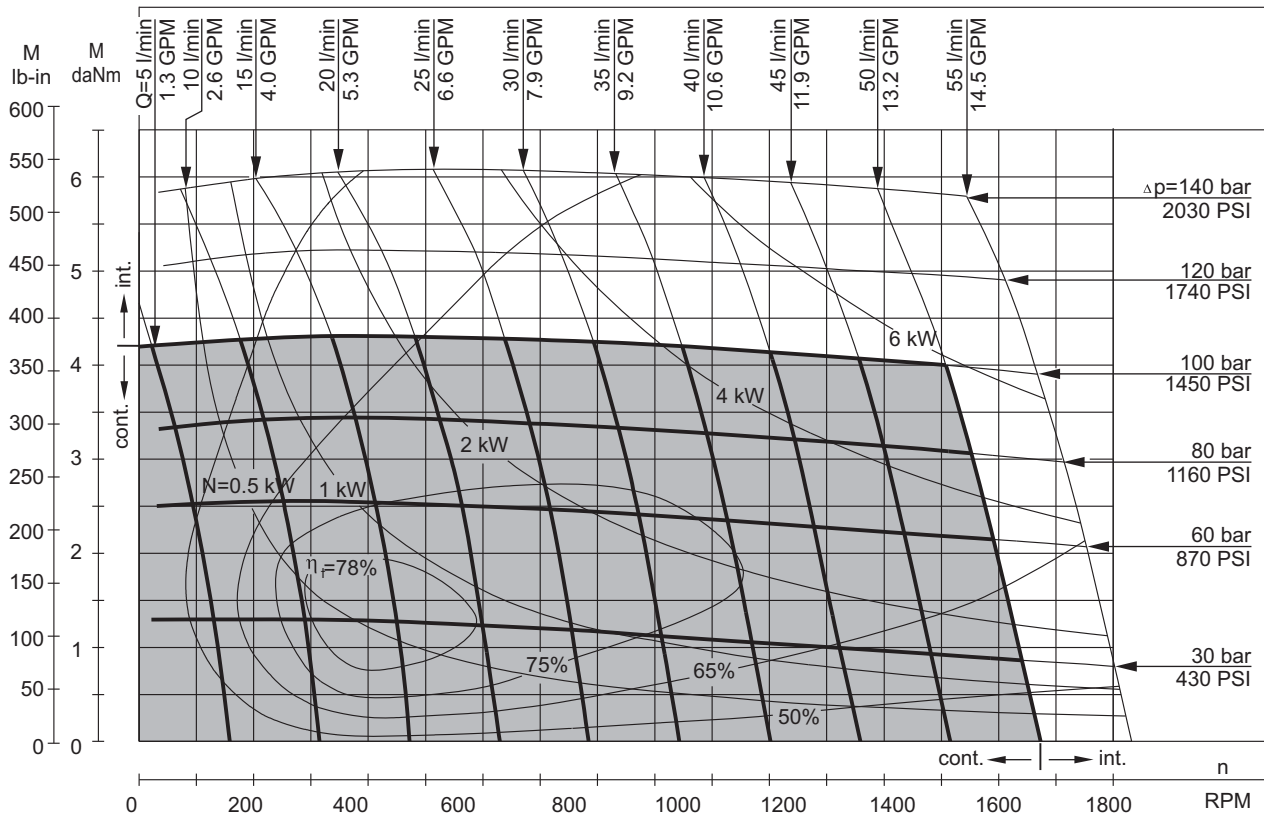

The function diagrams data is for average performance of randomly selected motors at back pressure 5÷10 bar [72.5÷145 PSI] and oil with viscosity of 32 mm<sup>2</sup>/s [150 SUS] at 50°C [122°F].



**FUNCTION DIAGRAMS**

**MP 40**

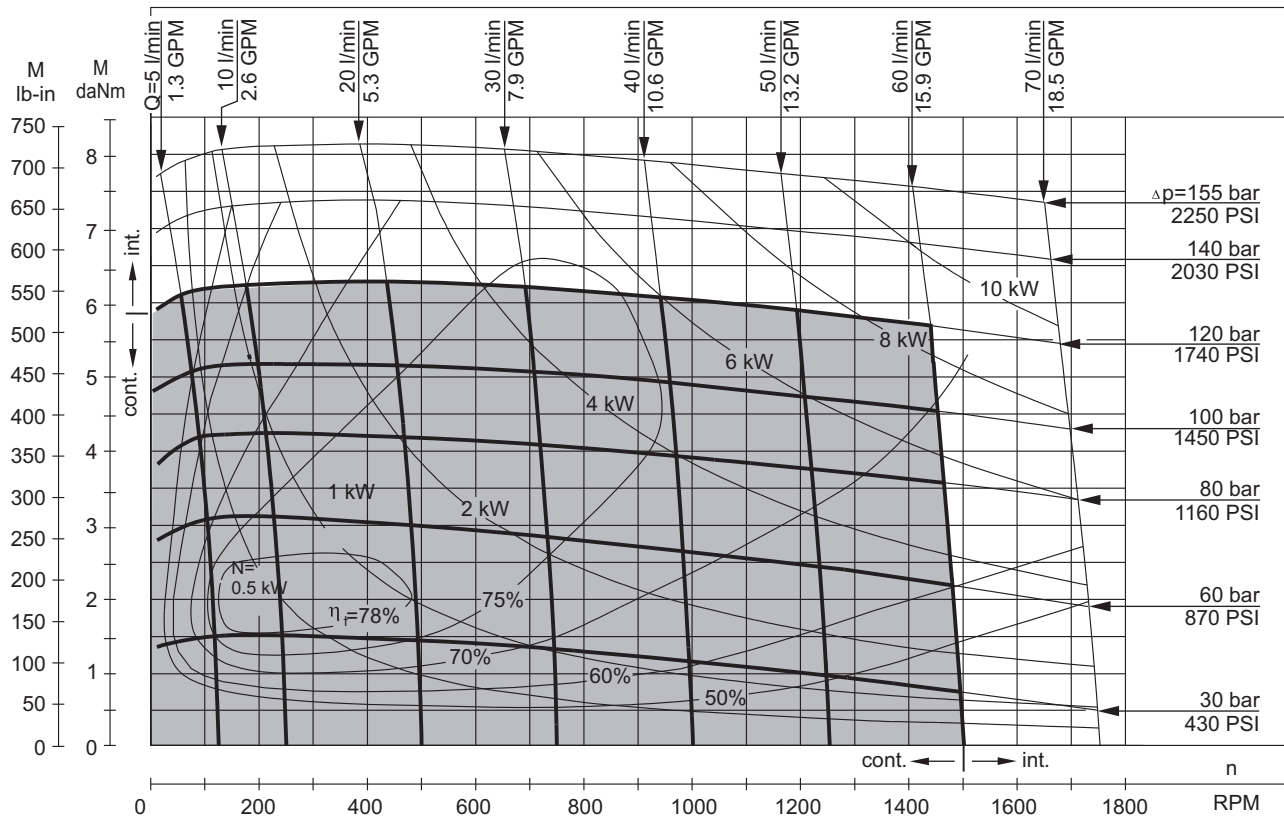

**MP 50**

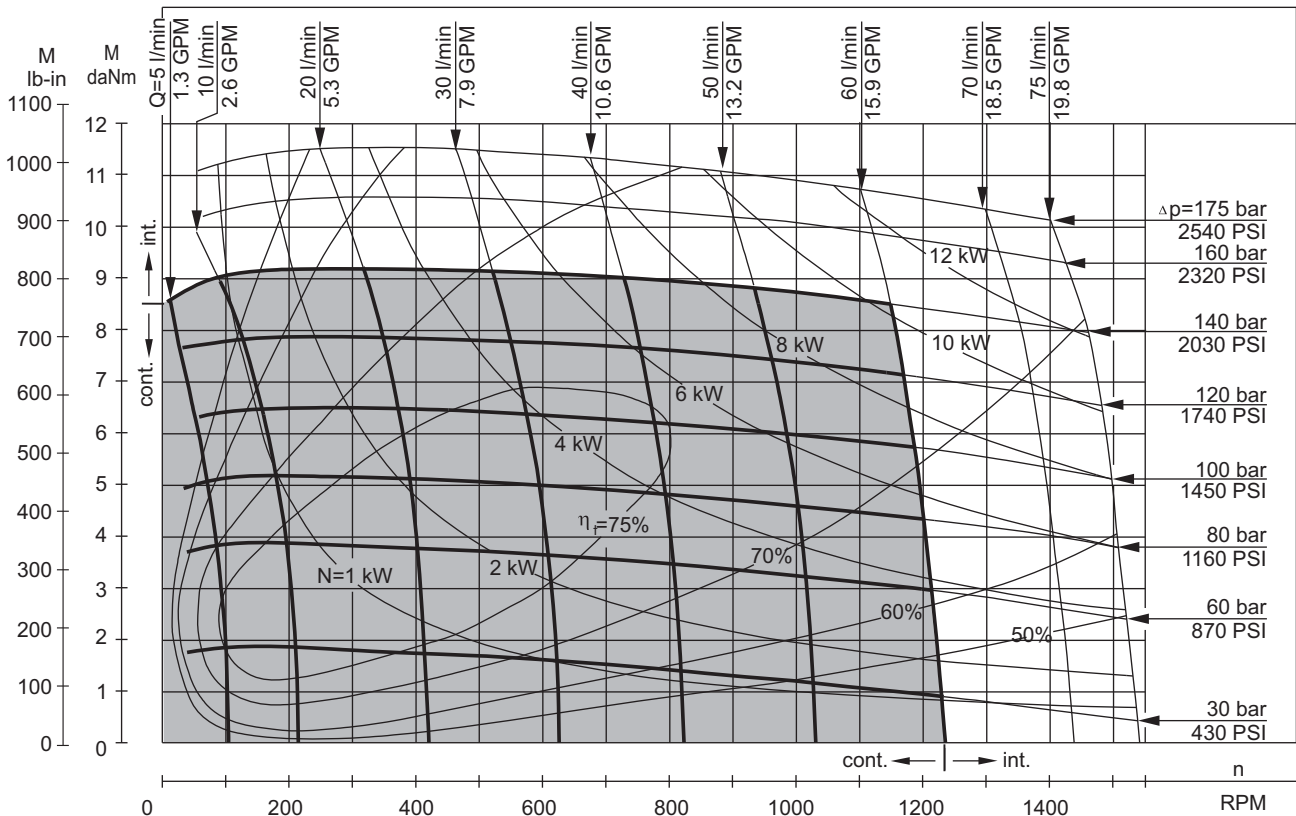

The function diagrams data is for average performance of randomly selected motors at back pressure 5÷10 bar [72.5÷145 PSI] and oil with viscosity of 32 mm<sup>2</sup>/s [150 SUS] at 50°C [122°F].

**FUNCTION DIAGRAMS**

**MP 80**

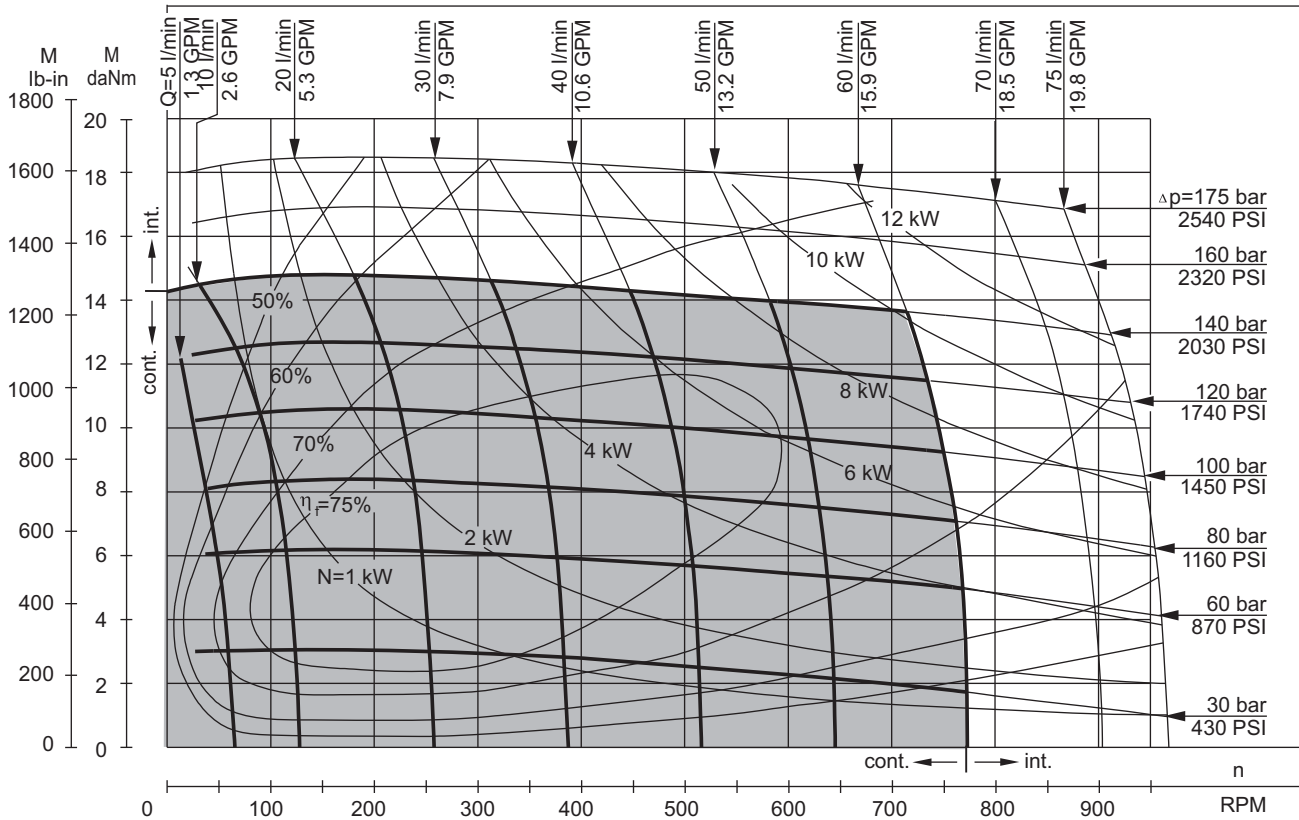

**MP 100**

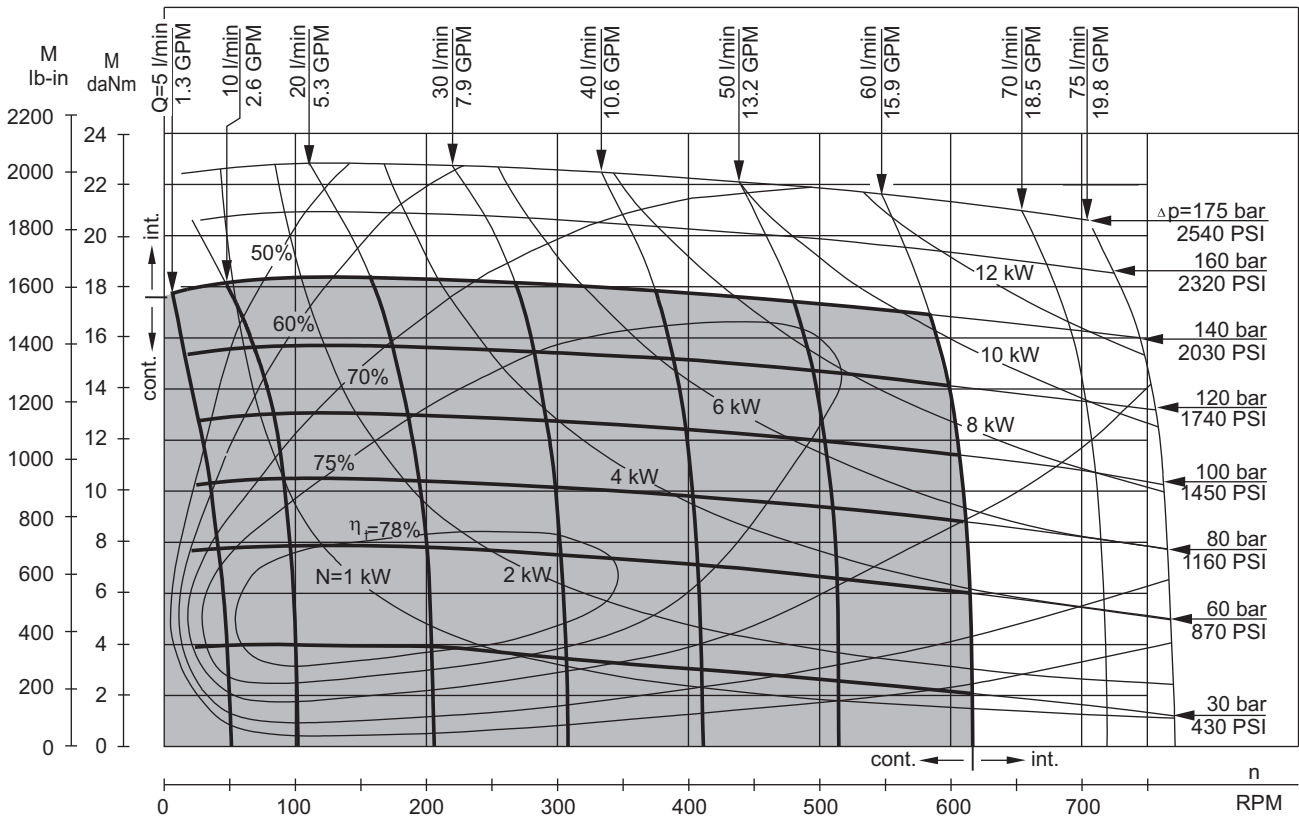

The function diagrams data is for average performance of randomly selected motors at back pressure 5÷10 bar [72.5÷145 PSI] and oil with viscosity of 32 mm<sup>2</sup>/s [150 SUS] at 50°C [122°F].



**FUNCTION DIAGRAMS**

**MP 125**

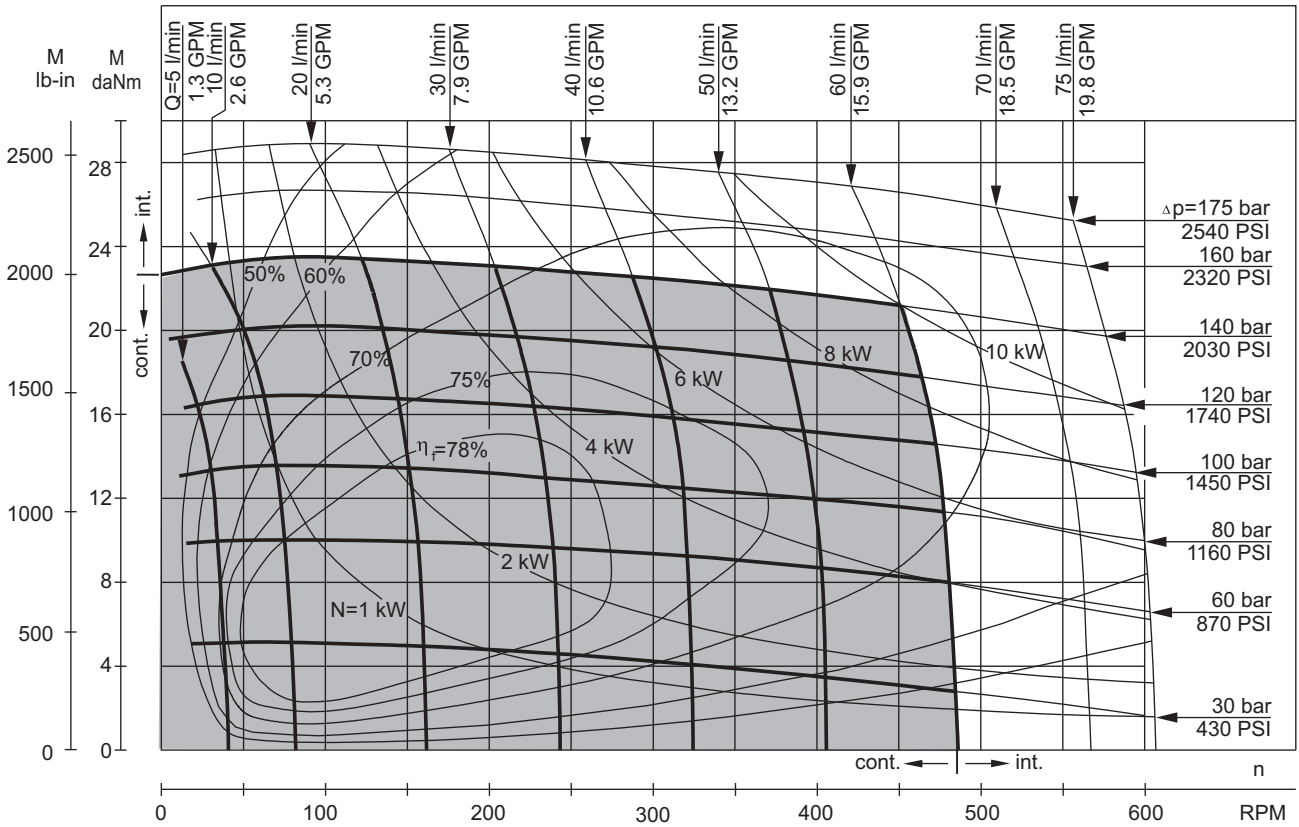

**MP 160**

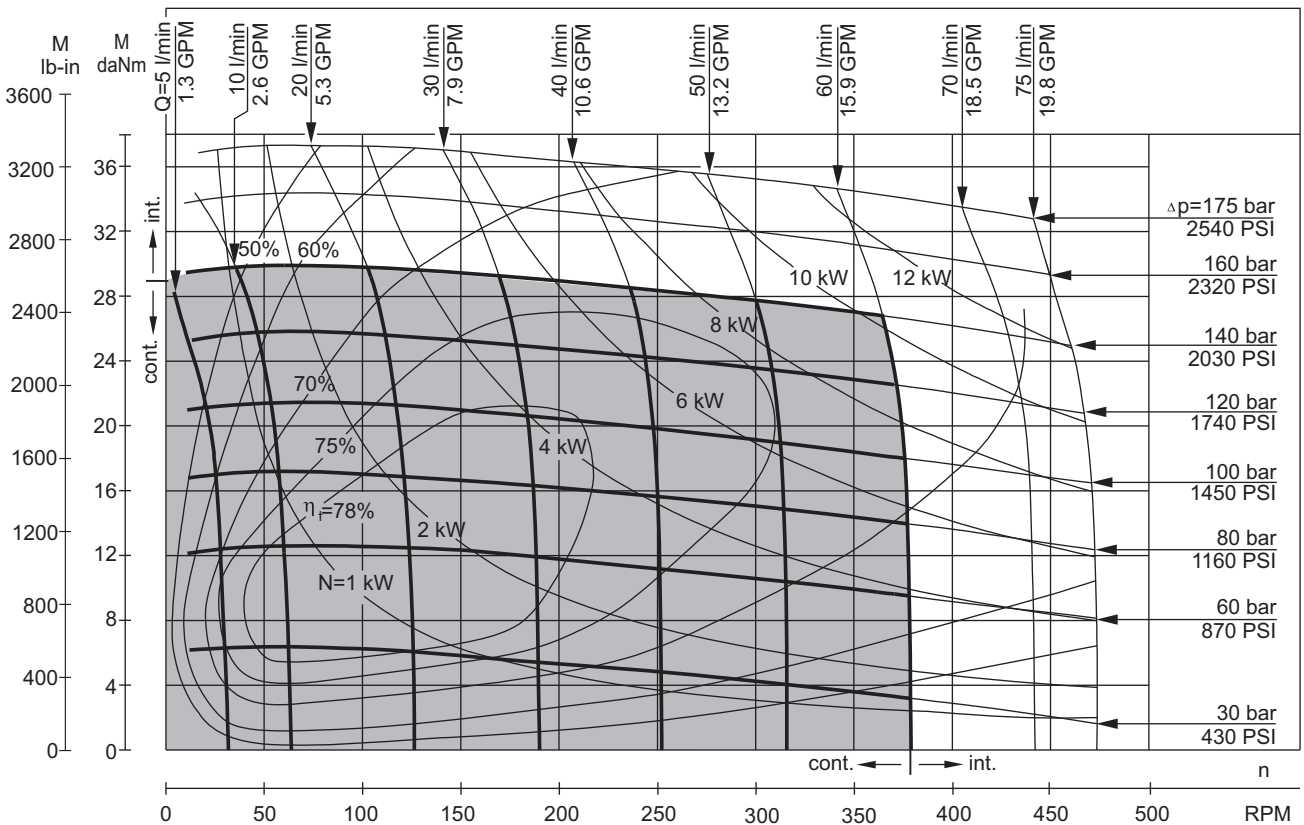

The function diagrams data is for average performance of randomly selected motors at back pressure 5÷10 bar [72.5÷145 PSI] and oil with viscosity of 32 mm<sup>2</sup>/s [150 SUS] at 50°C [122°F].

**FUNCTION DIAGRAMS**

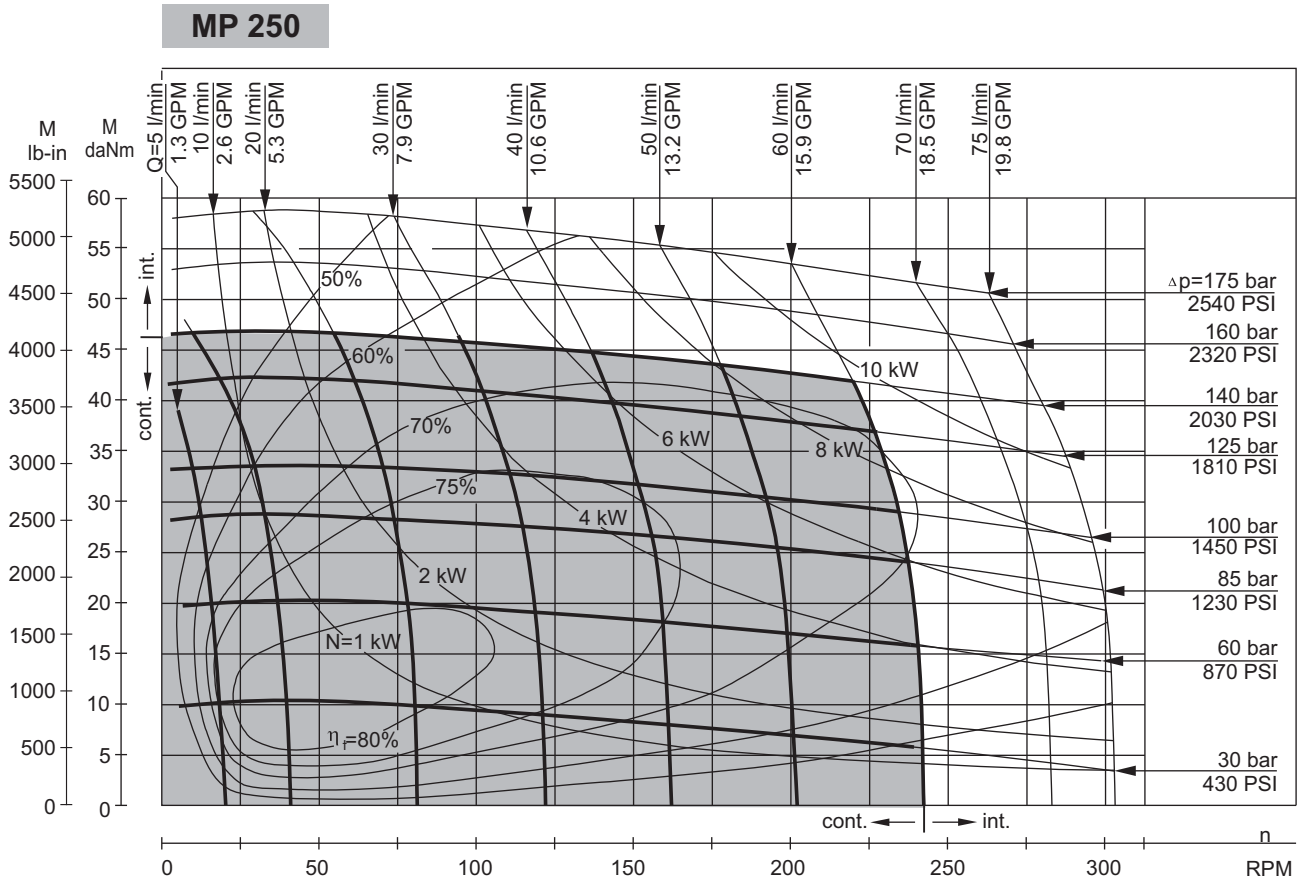
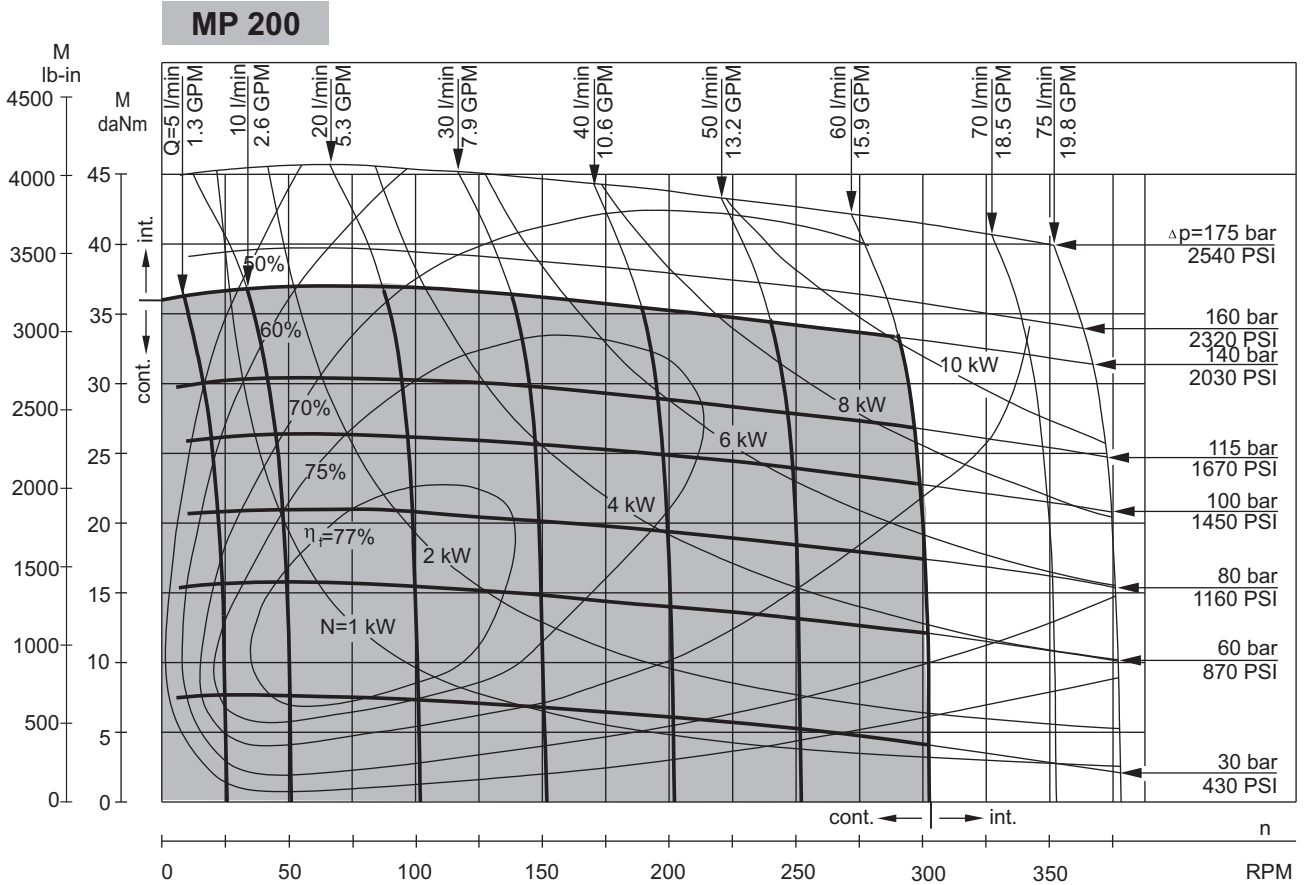

The function diagrams data is for average performance of randomly selected motors at back pressure 5÷10 bar [72.5÷145 PSI] and oil with viscosity of 32 mm<sup>2</sup>/s [150 SUS] at 50°C [122°F].

**FUNCTION DIAGRAMS**

**MP 315**

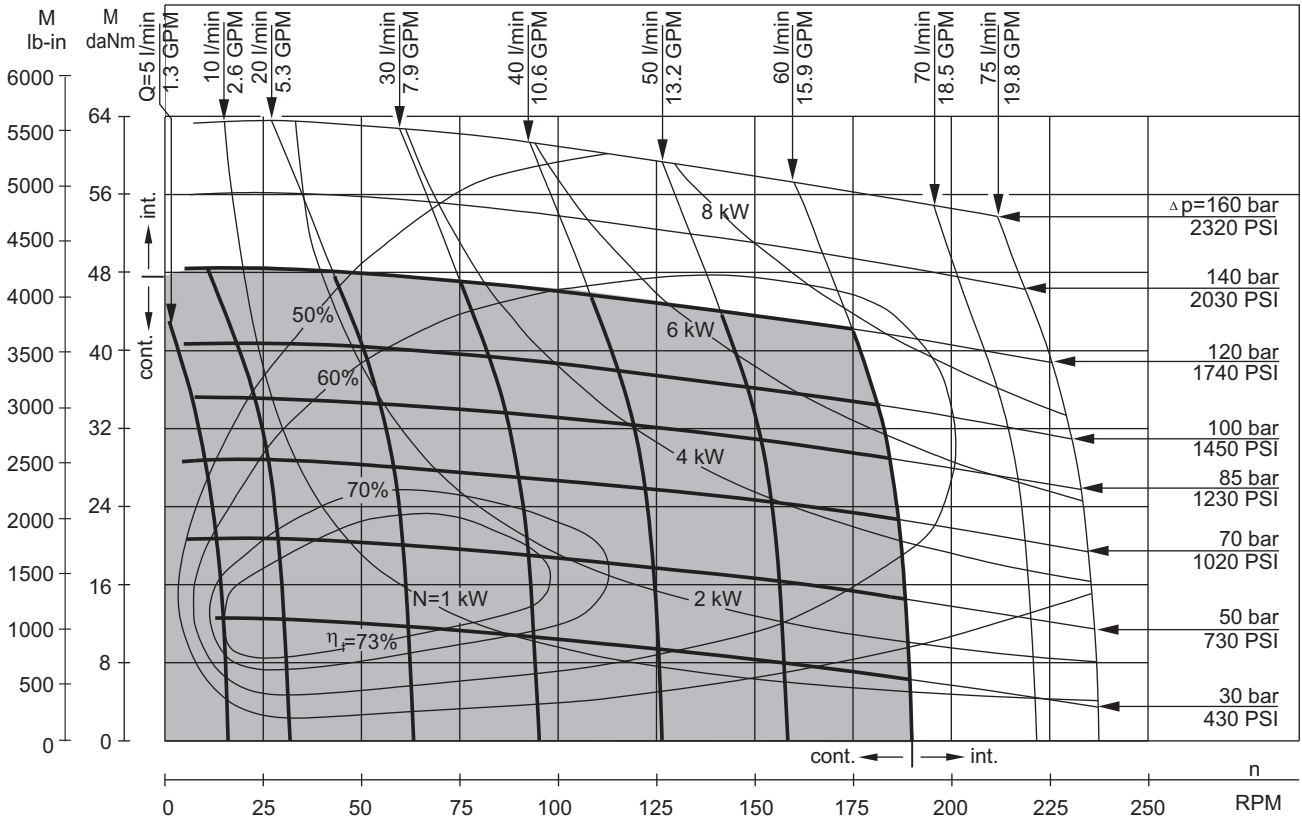

**MP 400**

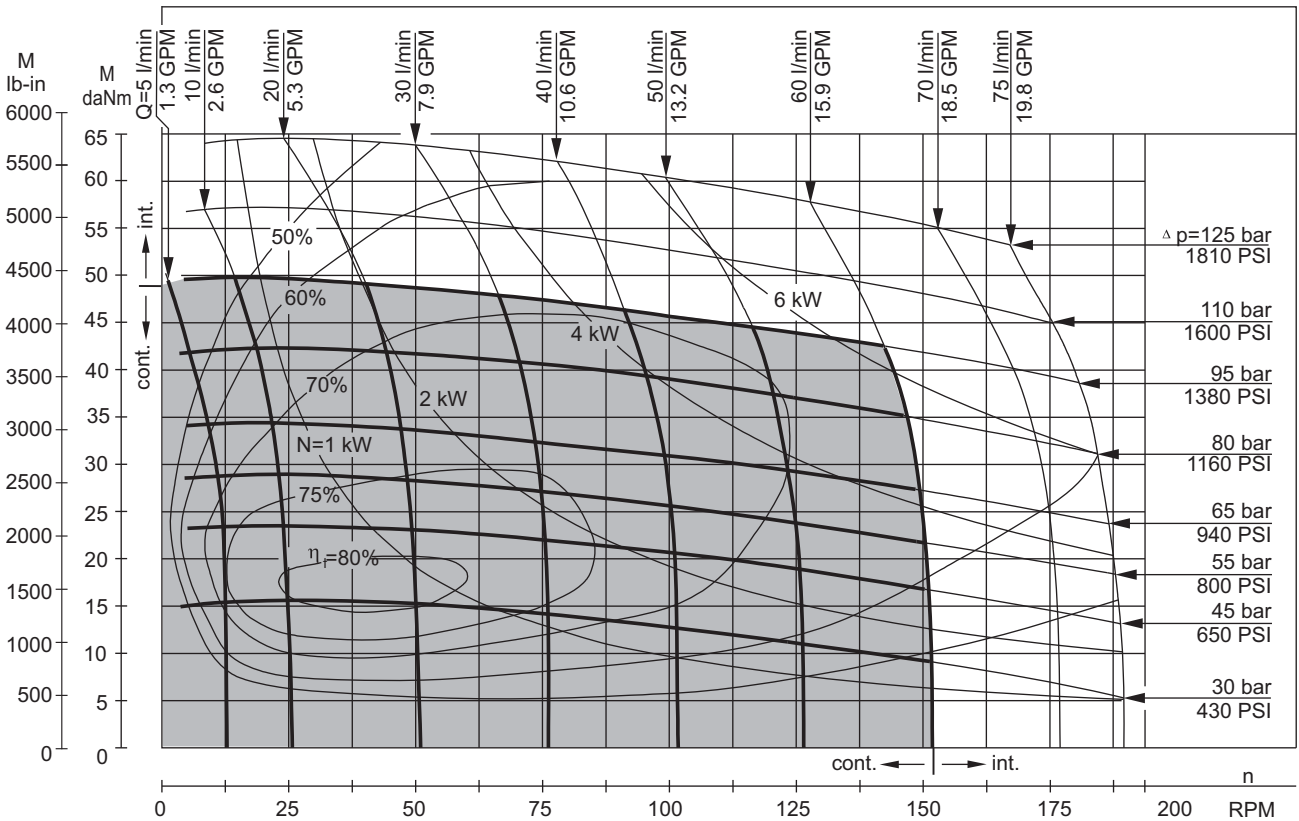

The function diagrams data is for average performance of randomly selected motors at back pressure 5÷10 bar [72.5÷145 PSI] and oil with viscosity of 32 mm<sup>2</sup>/s [150 SUS] at 50°C [122°F].

**FUNCTION DIAGRAMS**

**MP 500**

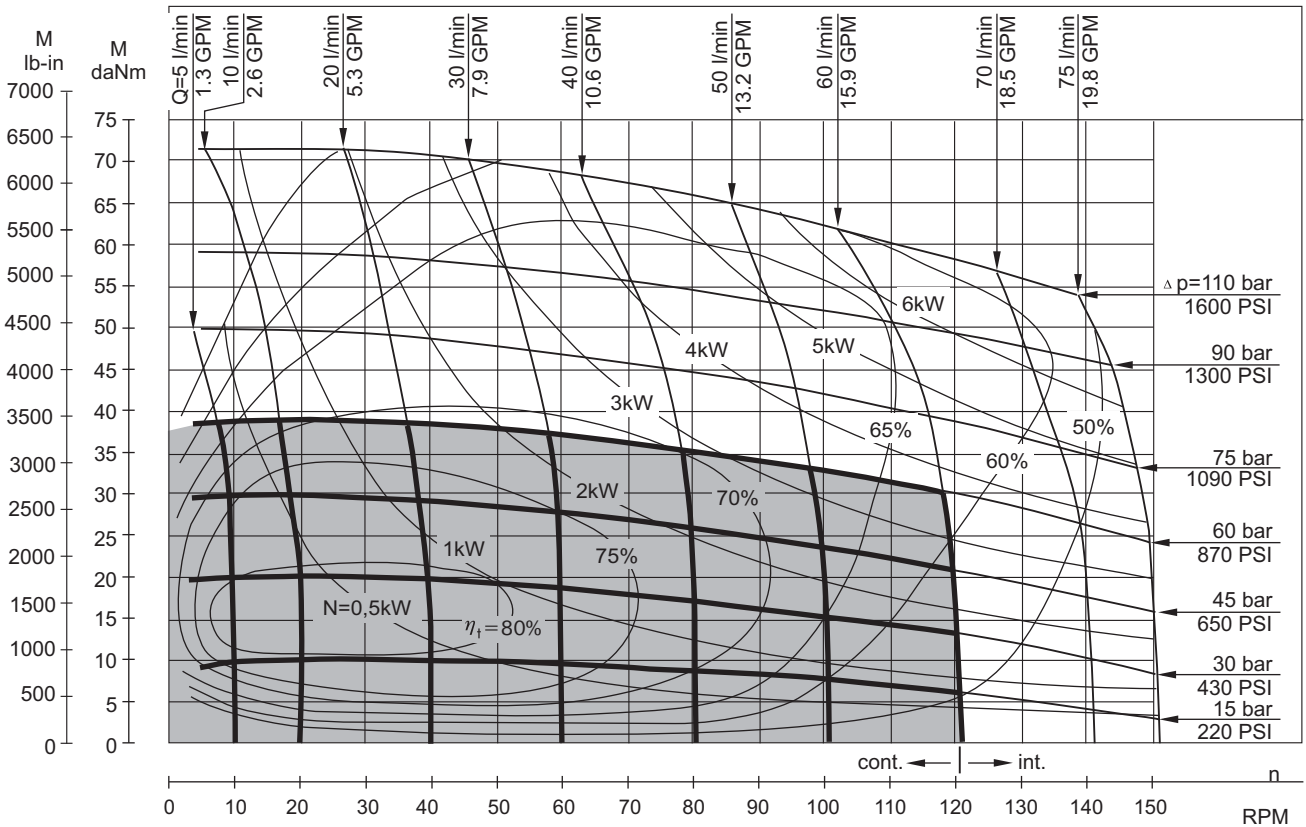

**MP 630**

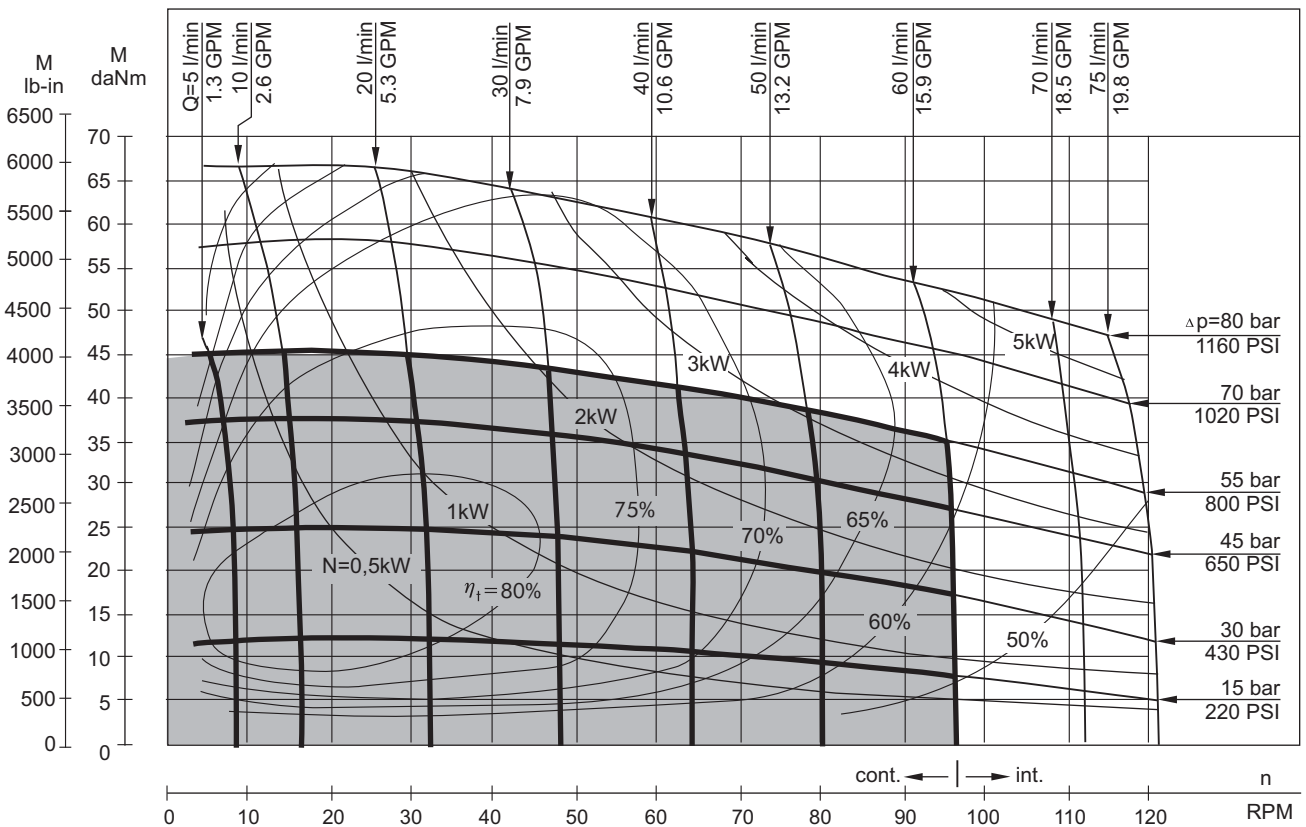

The function diagrams data is for average performance of randomly selected motors at back pressure 5÷10 bar [72.5÷145 PSI] and oil with viscosity of 32 mm<sup>2</sup>/s [150 SUS] at 50°C [122°F].

**DIMENSIONS AND MOUNTING DATA**

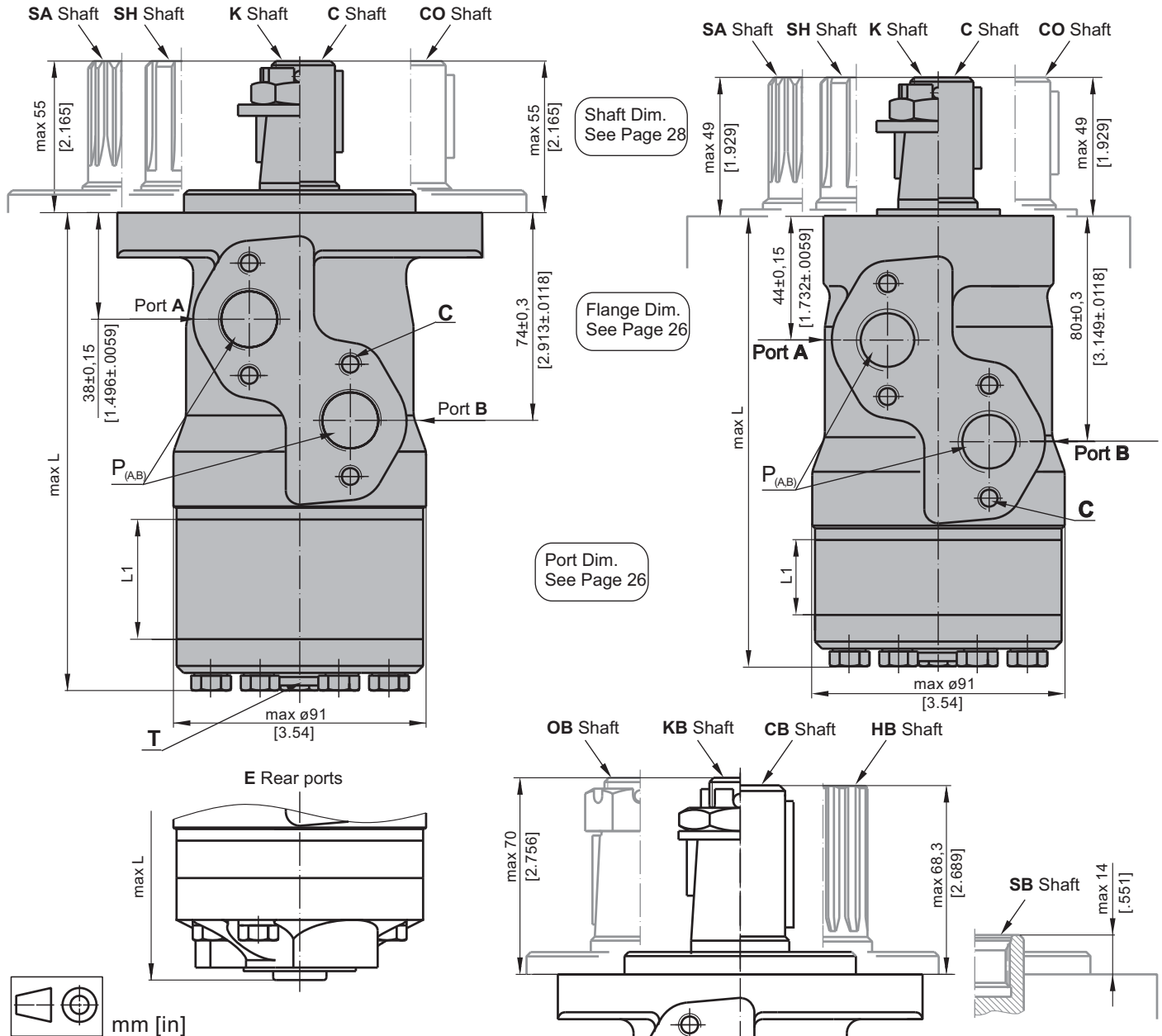

**C** : 4xM8 - 13 mm [.51 in] depth  
**P<sub>(A,B)</sub>** : 2xG1/2 or 2xM22x1,5 - 15 mm [.59 in] depth  
**T** : G1/4 or M14x1,5 - 12 mm [.47 in] depth (plugged)

**Standard Rotation**  
 Viewed from Shaft End  
 Port A Pressurized - **CW**  
 Port B Pressurized - **CCW**

**Reverse Rotation**  
 Viewed from Shaft End  
 Port A Pressurized - **CCW**  
 Port B Pressurized - **CW**

Type	L, mm [in]	Type	L, mm [in]	Type	L, mm [in]	Type	L, mm [in]	L <sub>r</sub> , mm [in]
MP(F) 25	134,0 [5.28]	MPQ 25	140,5 [5.53]	MP(F)E 25	150,0 [5.91]	MPQE 25	156,5 [6.16]	5,20 [.21]
MP(F) 32	135,0 [5.31]	MPQ 32	141,5 [5.57]	MP(F)E 32	151,5 [5.96]	MPQE 32	157,5 [6.20]	6,30 [.25]
MP(F) 40	136,5 [5.37]	MPQ 40	142,5 [5.61]	MP(F)E 40	152,5 [6.00]	MPQE 40	158,5 [6.24]	7,40 [.29]
MP(F) 50	135,5 [5.33]	MPQ 50	142,0 [5.59]	MP(F)E 50	151,5 [5.96]	MPQE 50	158,0 [6.22]	6,67 [.26]
MP(F) 80	139,5 [5.49]	MPQ 80	146,0 [5.75]	MP(F)E 80	155,5 [6.12]	MPQE 80	162,0 [6.38]	10,67 [.42]
MP(F) 100	142,0 [5.59]	MPQ 100	148,5 [5.85]	MP(F)E 100	158,5 [6.24]	MPQE 100	164,5 [6.48]	13,33 [.52]
MP(F) 125	145,5 [5.73]	MPQ 125	152,0 [5.98]	MP(F)E 125	161,5 [6.36]	MPQE 125	168,0 [6.61]	16,67 [.66]
MP(F) 160	150,0 [5.91]	MPQ 160	156,5 [6.16]	MP(F)E 160	166,5 [6.56]	MPQE 160	172,5 [6.79]	21,33 [.84]
MP(F) 200	155,5 [6.12]	MPQ 200	162,0 [6.38]	MP(F)E 200	171,5 [6.75]	MPQE 200	178,0 [7.01]	26,67 [1.05]
MP(F) 250	162,0 [6.38]	MPQ 250	168,5 [6.63]	MP(F)E 250	178,5 [7.03]	MPQE 250	184,5 [7.26]	33,33 [1.31]
MP(F) 315	171,5 [6.75]	MPQ 315	178,0 [7.01]	MP(F)E 315	187,5 [7.38]	MPQE 315	194,0 [7.64]	42,67 [1.68]
MP(F) 400	182,0 [7.17]	MPQ 400	188,5 [7.42]	MP(F)E 400	198,5 [7.81]	MPQE 400	204,5 [8.05]	53,33 [2.10]
MP(F) 500	195,5 [7.70]	MPQ 500	202,0 [7.95]	MP(F)E 500	211,5 [8.33]	MPQE 500	218,0 [8.58]	66,63 [2.62]
MP(F) 630	213,0 [8.39]	MPQ 630	219,0 [8.62]	MP(F)E 630	229,0 [9.02]	MPQE 630	235,0 [9.25]	84,00 [3.31]



**MOUNTING**

Oval Mount (2 Holes)

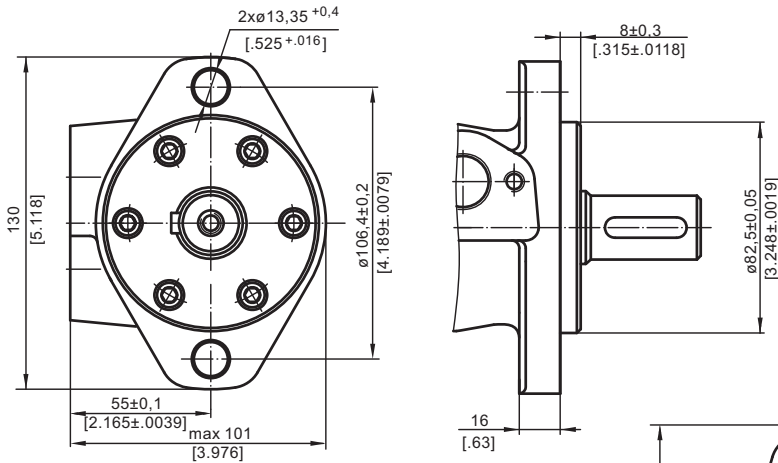

**F** - Oval Mount (4 Holes)

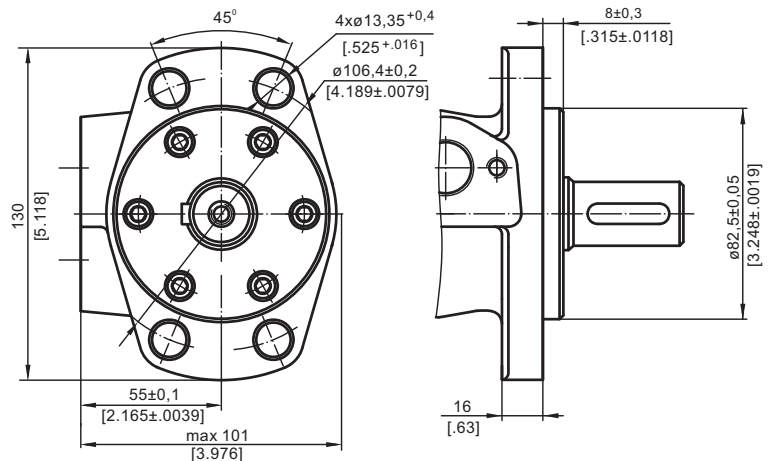

**Q** - Square Mount (4 Bolts)

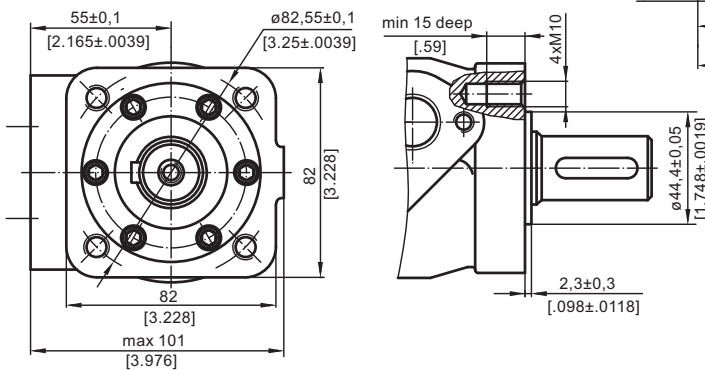

**PORTS**

Side Ports

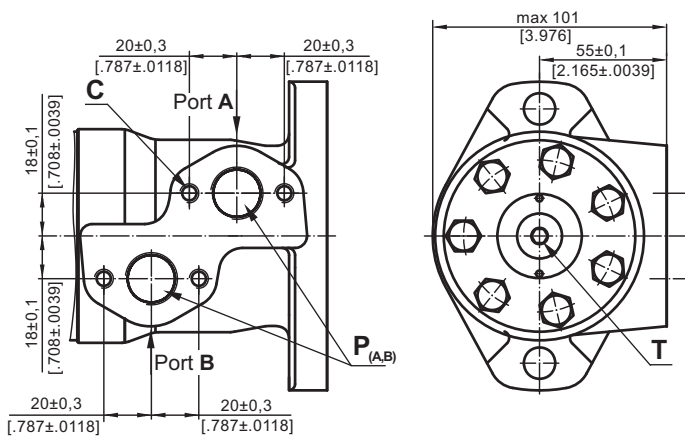

**E** Rear Ports

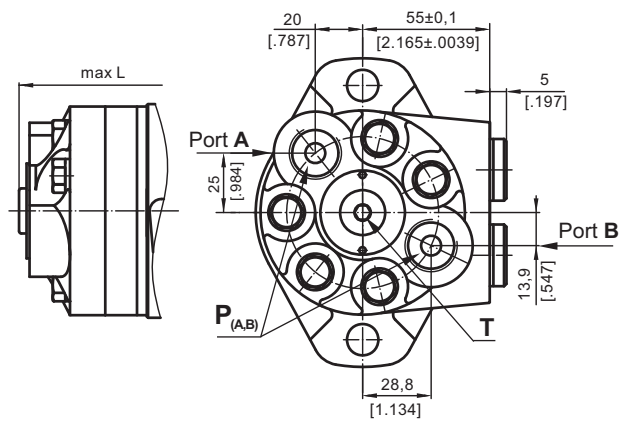

- C** : 4xM8 - 13 mm [.51 in] depth
- P<sub>(A,B)</sub>** : 2xG1/2 or 2xM22x1,5 - 15 mm [.59 in] depth
- T** : G1/4 or M14x1,5 - 12 mm [.47 in] depth (plugged)

- Standard Rotation**  
Viewed from Shaft End  
Port A Pressurized - CW  
Port B Pressurized - CCW

- Reverse Rotation**  
Viewed from Shaft End  
Port A Pressurized - CCW  
Port B Pressurized - CW



**DIMENSIONS AND MOUNTING DATA - MPW**

**W - Wheel Mount**

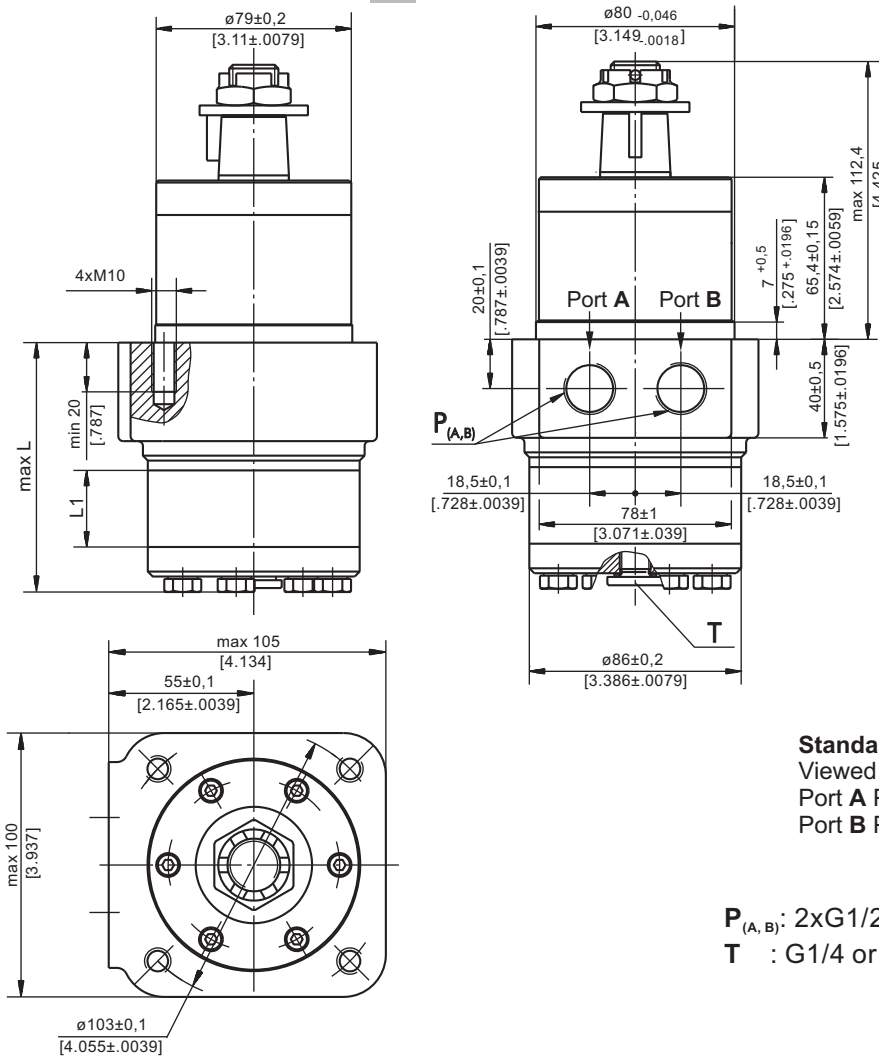

Type	L, mm [in]	L <sub>1</sub> , mm [in]
MPW 25	77,0 [3.03]	5,20 [.21]
MPW 32	78,0 [3.07]	6,30 [.25]
MPW 40	79,5 [3.13]	7,40 [.29]
MPW 50	78,5 [3.09]	6,67 [.26]
MPW 80	82,5 [3.25]	10,67 [.42]
MPW 100	85,0 [3.35]	13,33 [.52]
MPW 125	88,5 [3.48]	16,67 [.66]
MPW 160	93,0 [3.66]	21,33 [.84]
MPW 200	98,5 [3.88]	26,67 [1.05]
MPW 250	105,0 [4.13]	33,33 [1.31]
MPW 315	114,5 [4.51]	42,67 [1.68]
MPW 400	125,0 [4.92]	53,33 [2.10]
MPW 500	138,5 [5.45]	66,63 [2.62]
MPW 630	156,0 [6.14]	84,00 [3.31]



**Standard Rotation**  
Viewed from Shaft End  
Port A Pressurized - CW  
Port B Pressurized - CCW

**Reverse Rotation**  
Viewed from Shaft End  
Port A Pressurized - CCW  
Port B Pressurized - CW

**P<sub>(A,B)</sub>**: 2xG1/2 or 2xM22x1,5 - 15 mm [.59 in] depth  
**T** : G1/4 or M14x1,5 - 12 mm [.47 in] depth (plugged)

**PERMISSIBLE SHAFT LOADS**

**MPWN**

**MPW**

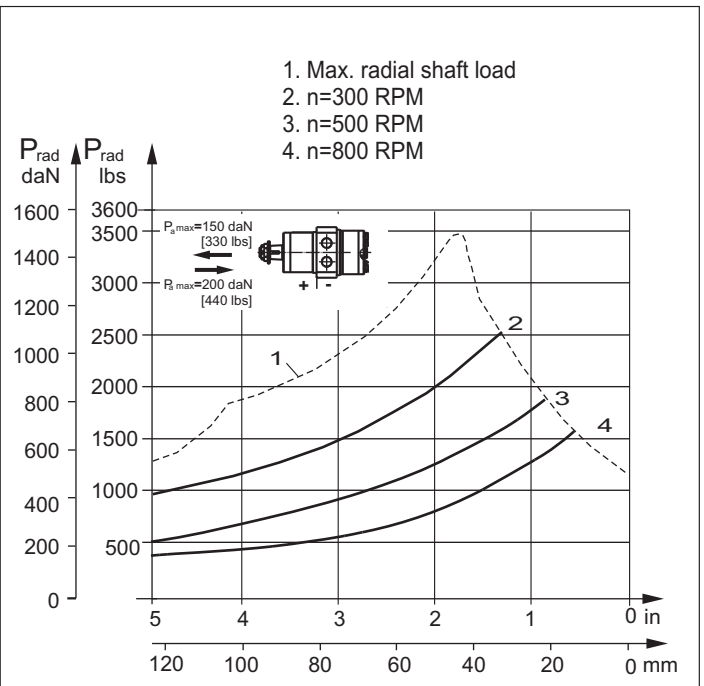
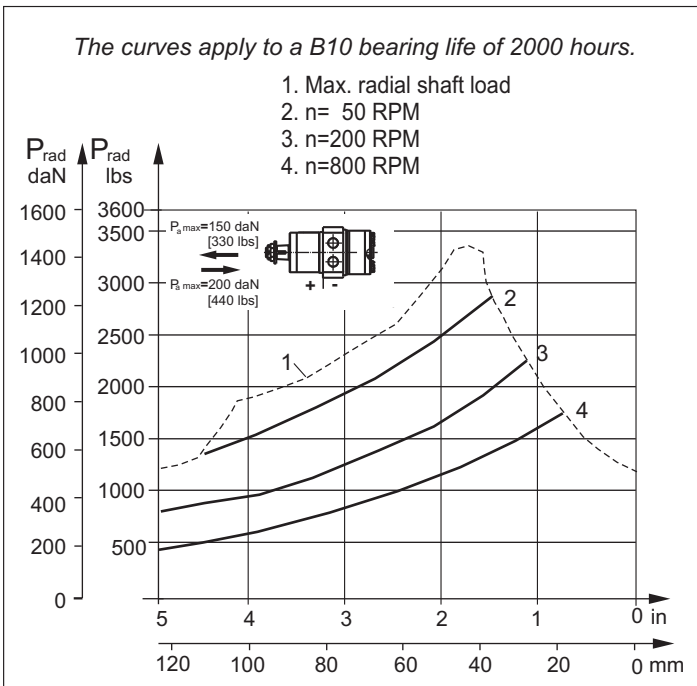

**SHAFT EXTENSIONS FOR MP AND MR MOTORS**

**C** -  $\varnothing 25$  straight, Parallel key A8x7x32 DIN 6885  
Max. Torque 34 daNm [3010 lb-in]

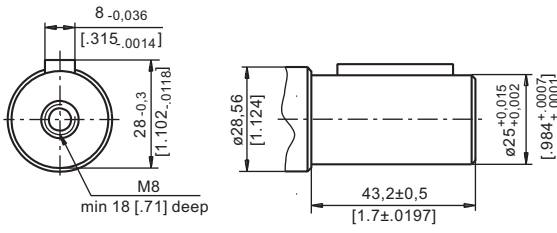

**CB** -  $\varnothing 32$  straight, Parallel key A10x8x45 DIN 6885  
Max. Torque 77 daNm [6815 lb-in]

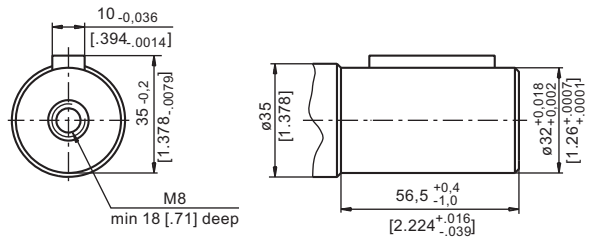

**CO** -  $\varnothing 1"$  straight, Parallel key  $1/4"x1/4"x1 1/4"$  BS46  
Max. Torque 34 daNm [3010 lb-in]

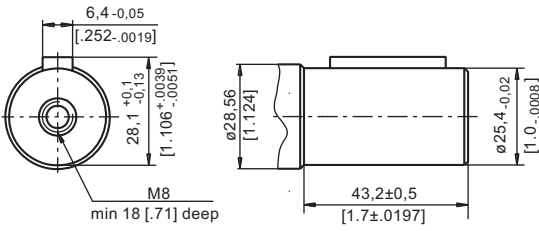

**SB** - splined A25x22xH10 DIN 5482  
Max. Torque 34 daNm [3010 lb-in]

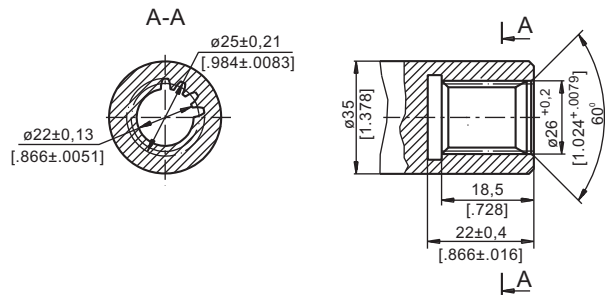

**SH** - splined, BS 2059 (SAE 6B)  
Max. Torque 40 daNm [3540 lb-in]

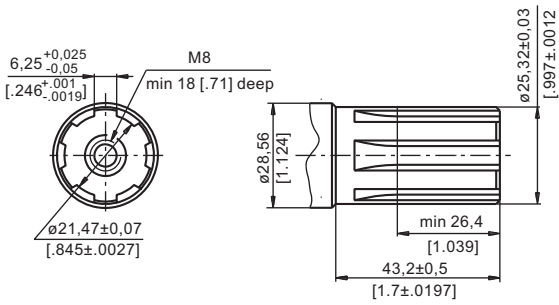

**KB** - tapered 1:10, Parallel key B6x6x20 DIN 6885  
Max. Torque 77 daNm [6815 lb-in]

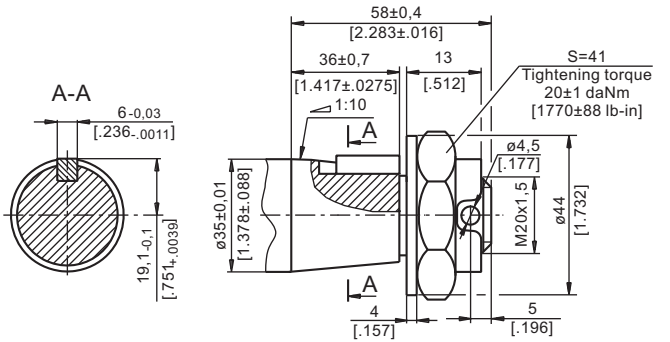

**K** - tapered 1:10, Parallel key B5x5x14 DIN 6885  
Max. Torque 40 daNm [3540 lb-in]

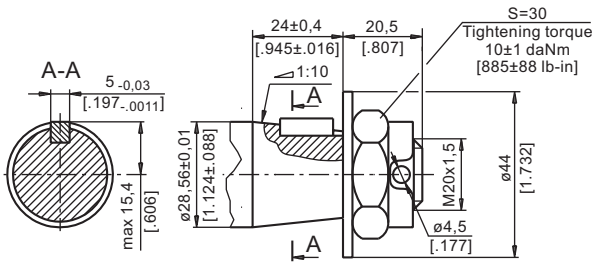

**OB** - tapered 1:8 SAEJ 501, Parallel key  $5/16"x5/16"x1 1/4"$  BS46  
Max. Torque 77 daNm [6815 lb-in]

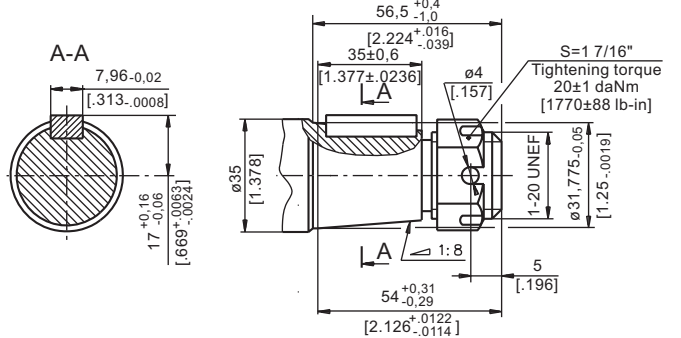

**SA** - splined, B25x22h9 DIN 5482  
Max. Torque 40 daNm [3540 lb-in]

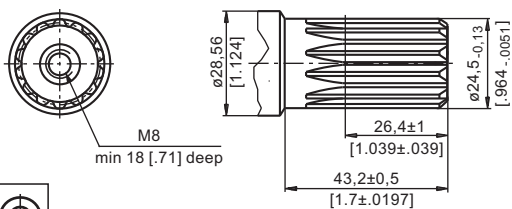

**HB** -  $\varnothing 1 1/4"$  splined 14T, ANSI B92.1-1976 Norm  
Max. Torque 77 daNm [6815 lb-in]

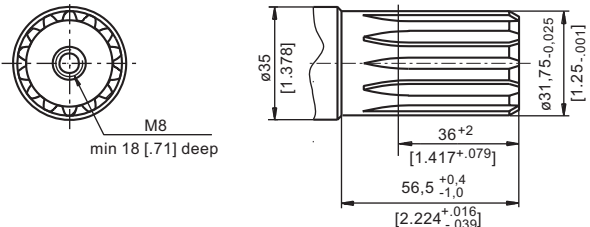

**PERMISSIBLE SHAFT LOADS FOR MP AND MR MOTORS**

The permissible radial shaft load  $P_{rad}$  depends on the speed  $n$ , RPM, distance  $L$  from the point of load to the mounting flange and shaft version.

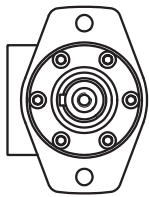
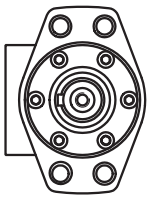
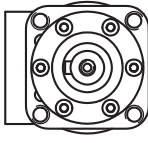
Mounting Flange			
Shaft Version	cylindrical - C, CO tapered - K, splined - SH	splined - HB cylindrical - CB	cylindrical - C, CO
Radial Shaft Load $P_{rad}$ , in mm	$\frac{800}{n} \times \frac{25000}{95+L}$ , daN*	$\frac{800}{n} \times \frac{18750}{95+L}$ , daN*	$\frac{800}{n} \times \frac{25000}{101+L}$ , daN*
Radial Shaft Load $P_{rad}$ , in inch	$\frac{800}{RPM} \times \frac{2215}{3.74+L}$ , lbs*	$\frac{800}{RPM} \times \frac{1660}{3.74+L}$ , lbs*	$\frac{800}{RPM} \times \frac{2215}{3.98+L}$ , lbs*

\*  $n < 200$  RPM; max  $P_{rad}$ =800 daN [1800 lbs]  
 $n \geq 200$  RPM;  $L < 55$  mm [2.2 in]

**MP AND MR**

Radial Shaft Load  $P_{rad}$  for C, CO Shaft Extensions by  $L=30$  mm [1.18 in] (24 mm [.94 in])

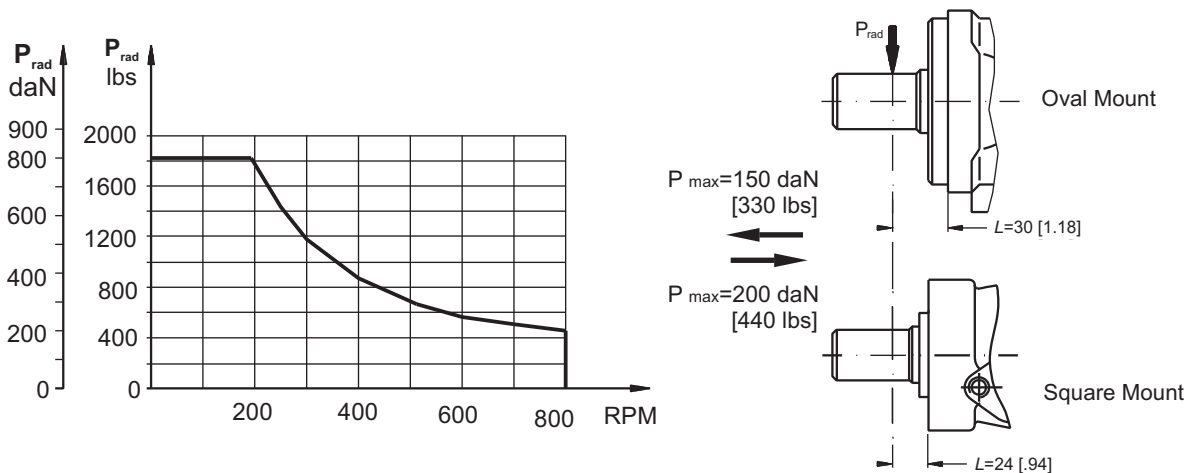

**MPN AND MRN**

The curves apply to a B10 bearing life of 2000 hours.

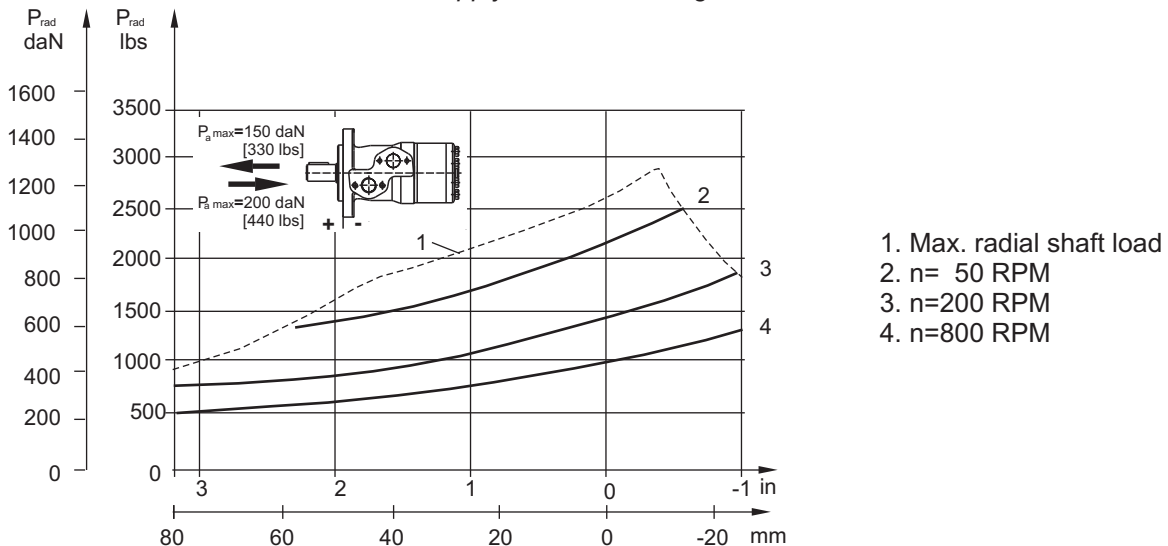

- 1. Max. radial shaft load
- 2.  $n= 50$  RPM
- 3.  $n=200$  RPM
- 4.  $n=800$  RPM

**MAX. PERMISSIBLE SHAFT SEAL PRESSURE FOR MP AND MR MOTORS**

**MP/MR...U1 motors with high pressure seal and without drain connection:**

The shaft seal pressure equals the average of input pressure and return pressure.

$$P_{\text{seal}} = \frac{P_{\text{input}} + P_{\text{return}}}{2}$$

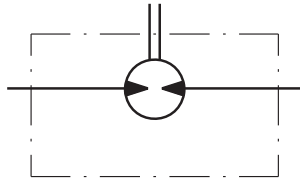

**MP/MR...U motors with high pressure seal and drain connection:**

The shaft seal pressure equals the pressure in the drain line.

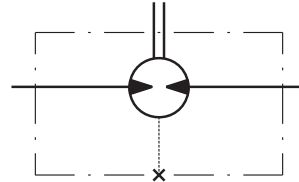

**MP/MR...1 motors with low pressure seal or standard shaft seal and without drain connection:**

The shaft seal pressure never exceeds the pressure in the return line.

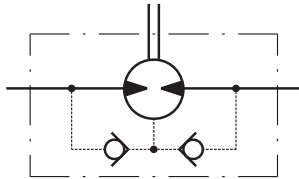

**MP/MR... motors with low pressure seal or standard shaft seal and with drain connection:**

The shaft seal pressure equals the pressure in the drain line.

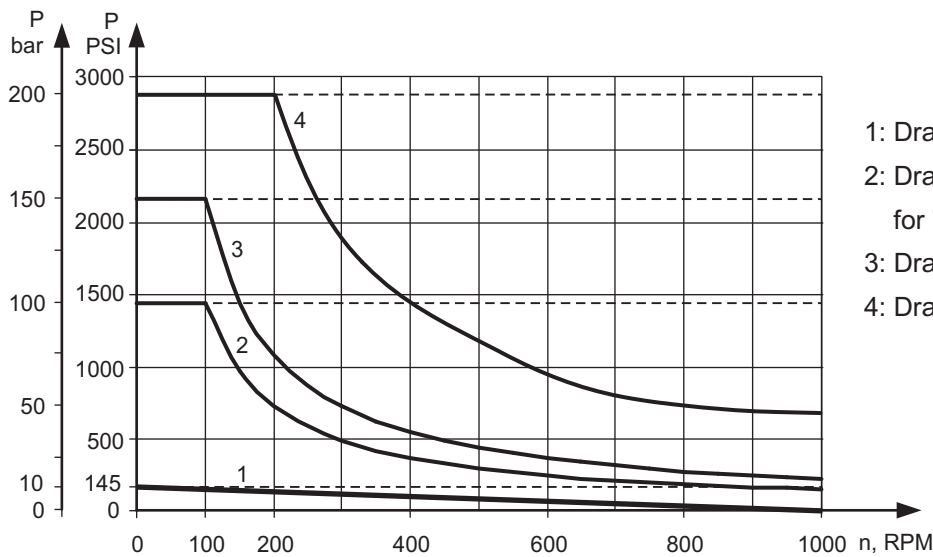
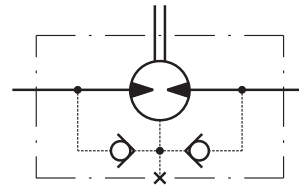

- 1: Drawing for Low Pressure Seal
- 2: Drawing for Standard Shaft Seal for "...B" shafts
- 3: Drawing for Standard Shaft Seal ("D" Seal)
- 4: Drawing for High Pressure Seal ("U" Seal)

— - continuous operations  
- - - - - intermittent operations

## ORDER CODE

	1	2	3	4	5	6	7	8	9	10
<b>M P</b>										

### Pos.1 - Mounting Flange

omit - Oval mount, two holes

**F** - Oval mount, four holes

**Q** - Square mount, four bolts

**W** - Wheel mount

### Pos.2 - Option (needle bearings)

omit - none

**N** - with needle bearings

### Pos.3 - Port type

omit - Side ports

**E** - Rear ports

### Pos.4 - Displacement code

**25\*** - 25,0 cm<sup>3</sup>/rev [ 1.52 in<sup>3</sup>/rev]

**32\*** - 32,0 cm<sup>3</sup>/rev [ 1.95 in<sup>3</sup>/rev]

**40\*** - 40,0 cm<sup>3</sup>/rev [ 2.44 in<sup>3</sup>/rev]

**50** - 49,5 cm<sup>3</sup>/rev [ 3.02 in<sup>3</sup>/rev]

**80** - 79,2 cm<sup>3</sup>/rev [ 4.83 in<sup>3</sup>/rev]

**100** - 99,0 cm<sup>3</sup>/rev [ 6.04 in<sup>3</sup>/rev]

**125** - 123,8 cm<sup>3</sup>/rev [ 7.55 in<sup>3</sup>/rev]

**160** - 158,4 cm<sup>3</sup>/rev [ 9.66 in<sup>3</sup>/rev]

**200** - 198,0 cm<sup>3</sup>/rev [12.10 in<sup>3</sup>/rev]

**250** - 247,5 cm<sup>3</sup>/rev [15.10 in<sup>3</sup>/rev]

**315** - 316,8 cm<sup>3</sup>/rev [19.30 in<sup>3</sup>/rev]

**400** - 396,0 cm<sup>3</sup>/rev [24.16 in<sup>3</sup>/rev]

**500** - 495,0 cm<sup>3</sup>/rev [30.20 in<sup>3</sup>/rev]

**630** - 623,6 cm<sup>3</sup>/rev [38.05 in<sup>3</sup>/rev]

### Pos. 5 - Shaft Extensions\*\* (see page 28)

**C** - ø25 straight, Parallel key A8x7x32 DIN6885

**VC** - ø25 straight, Parallel key A8x7x32 DIN6885 with corrosion resistant bushing

**CO** - ø1" straight, Parallel key ¼"x¼"x1¼" BS46

**VCO** - ø1" straight, Parallel key ¼"x¼"x1¼" BS46 with corrosion resistant bushing

**SH** - ø25,32 splined BS 2059 (SAE 6B)

**VSH** - ø25,32 splined BS 2059 (SAE 6B) with corrosion resistant bushing

**K** - ø28,56 tapered 1:10, Parallel key B5x5x14 DIN6885

**SA** - ø24,5 splined B 25x22 DIN 5482

**VSA** - ø24,5 splined B 25x22 DIN 5482 with corrosion resistant bushing

**CB** - ø32 straight, Parallel key A10x8x45 DIN6885

**KB** - ø35 tapered 1:10, Parallel key B6x6x20 DIN6885

**SB** - splined A 25x22 DIN 5482

**OB** - ø1¼" tapered 1:8, Parallel key <sup>5</sup>/<sub>16</sub>"x<sup>5</sup>/<sub>16</sub>"x1¼" BS46

**HB** - ø1¼" splined 14T ANSI B92.1 - 1976

### Pos. 6 - Shaft Seal Version (see page 30)

omit - Low pressure shaft seal or Standard shaft seal for "...B" shaft

**D** - Standard shaft seal

**U** - High pressure shaft seal (without check valves)

### Pos. 7 - Drain Port

omit - with drain port

**1** - without drain port

### Pos. 8 - Ports

omit - BSPP (ISO 228)

**M** - Metric (ISO 262)

### Pos. 9 - Special Features (see page 119)

### Pos.10 - Design Series

omit - Factory specified

## NOTES:

\* Not with Low Pressure Seal

\*\* The permissible output torque for shafts must not be exceeded!

The following combinations are not allowed:

- **Q** flange with "...B" shafts;
- **W** flange with "...B" shafts or **E** rear ports;
- **N** option with "...B" shafts, Low Pressure Seal or **U** option;
- "...B" shafts with **D** and **U** shaft seals.

The hydraulic motors are mangano-phosphatized as standard.